



TECHNICAL CATALOG



VA-MA

ABOUT VA-MA

VA-MA is a joint-stock enterprise specialized in manufacturing all kind of water pumps, controlling equipments, all kind of peripheral pumps, Centrifugal pumps, liquid pumps Submersible pumps, Self-priming pumps, Jet pumps, Multi stage pumps, Fountain pumps, Garden pumps, Fire pumps and also all kind of Pumps accessories like, Pressure switch, Tanks, Pressure manometer Gauge, 5 way connector, diffuser, venture tub, Capacitors, Float Switch, Mechanical seal, air page, Water supply for industry, Swimming pool pumps, Sand filters, Swimming accessories, etc.

ABOUT TERVINA



Tervina is our official agent in Egypt for more than 18 years We are a leading company of Surface and submersible pumps and electric motors with over 20 years' experience in the Egyptian market. We offer to our customers a big And specific range of pumps for a large variety of uses: domestic applications industrial fields groundwater wastewater and sewage Applications for civil plants building-service sector agricultural And Irrigation Applications Swimming Pools And Spa Baths.

Alfred Remon

CEO & Founder

Alfred Remon



Made in Italy

WHY US?

VA-MA is One Of Biggest Companies In World works in water pumps and has a maintenance center for our products To Give Our Customers After Sales Servicer Real Guarantee

OUR CAPACITY

Our capacity of almost 800,000 water pumps & accessories, it produces 12 series and 300 specification, and 20 series and 3,000 specification for industrial application, its products are used in agriculture, aqua farm, dwelling, and fire products, building, chemical industry, metallurgy, ore resources, refrigerator water supply for industrial.

OUR MISSION

One Of Our Keys Strengths Is Our Ability To Offer Products And Solutions In Different Materials To Meet Different Environmental And Design Needs For Our Customers In A Wide Range Of Fields Of Application. Cast Iron, Stainless Steel Different Grades Of Stainless Steel ,Lexan Pc And Other Materials Can Be Used To Create Different Product Versions According To Customer Requirements Another Reason To See The Quality Of Our Work First Hand And View Our Continuous Product Innovation And Improved Final Performance With Satisfaction.

OUR VISION

Manufacturing Vama-Pumps In Egypt to Satisfy All Our Customers Requests







PER 50 TR
PERIPHERAL

page 12



JET 037
SELF PRIMING

page 16



JET 100
SELF PRIMING

page 18



JET 150-200-300
ELLETROMPE VOLUMETRICH

page 20



SN SERIES
MONOBLOC

page 24



BLC
STAINLESS STEEL

page 28



DWK
STAINLESS STEEL

page 30



DWB
STAINLESS STEEL

page 32



CA
STAINLESS STEEL

page 35



CVF TYPE
MULTISTAGE

page 42



SCB
SWIMMING POOL

page 58



SBP
SWIMMING POOL

page 60



48 SUB
SWIMMING POOL

page 62



LP
SWIMMING POOL

page 64



WTB
SWIMMING POOL

page 66

PRODUCTS INDEX



WP
SWIMMING POOL *page 69*



JA
SWIMMING POOL *page 72*



QJD
SUBMERSIBLE
page 78



BH
SUBMERSIBLE
page 86

BP
SUBMERSIBLE
page 100



Pressure Gauge
ACCESSORIES *page 112*



5 way connector
ACCESSORIES *page 112*



Pressure Tank
ACCESSORIES *page 113*



PS02 PC-2
PRESSURE SWITCH *page 114*



PS02B PS9A
PRESSURE SWITCH *page 115*



PS-13
AUTOMATIC PUMP CONTROL
page 116



PS-15
AUTOMATIC PUMP CONTROL
page 117



PS-19
AUTOMATIC PUMP CONTROL *page 118*



PS-53
AUTOMATIC PUMP CONTROL *page 119*



PS-58
AUTOMATIC PUMP CONTROL *page 120*



PS-59
AUTOMATIC PUMP CONTROL *page 121*

Peripheral





PERIPHERAL
Pumps

PER 50 TR →

Suitable for use with clean water that does not contain abrasive particles and liquids that are not chemically aggressive towards the materials from which the pump is made.

MADE IN ITALY

PER 50 TR

DESCRIPTION & APPLICATIONS:

Peripheral positive displacement pumps with frontal pumps for small household systems and simple industrial applications; characterized by a considerable ratio between performance and required output.



MAIN FEATURES:

- Pump has an epoxy electro coating treatment
- Flow rate up to 35 l/min
- Head up to 37 m
- Max water temperature 50 °c
- Ambient temperature up to 40 °c

COMPONENT CONSTRUCTION

- Pump body Cast iron G20
- Pump bracket Cast iron G20
- Impeller Brass H59
- Pump shaft Stainless steel AISI 304
- Mechanical seal Ceramic / Graphite

MOTOR

- Two-pole induction motor
- External cooling
- Insulation class F
- Protection degree IP44
- Single phase 220V/50Hz
- Thermal protection
- Continuous service S1



PER 50 TR

SPECIFICATIONS

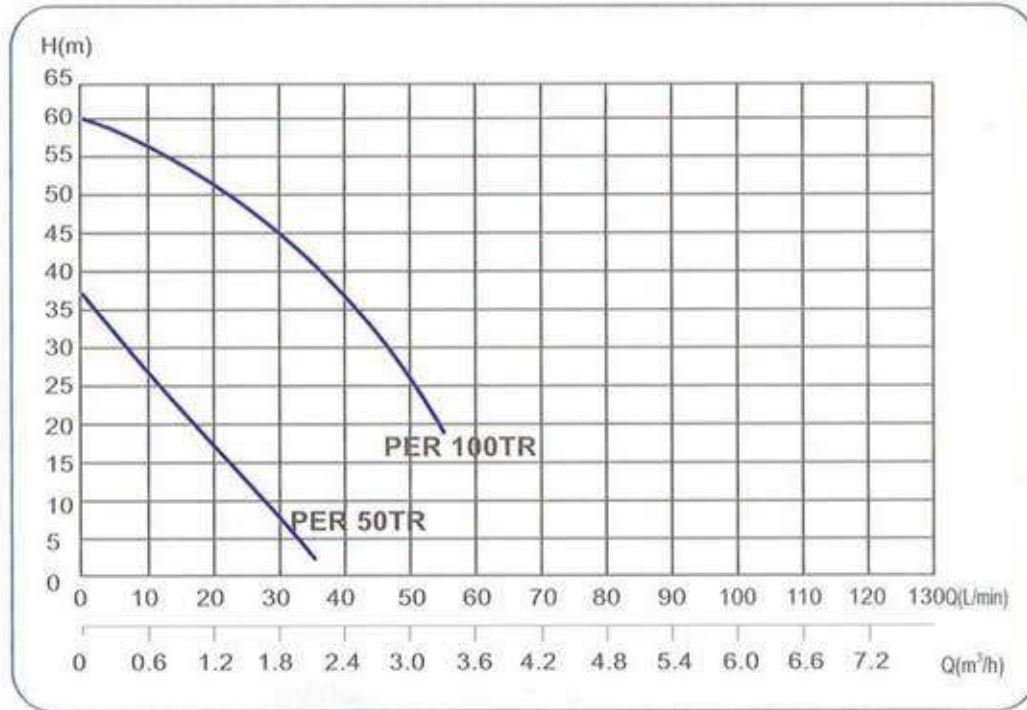

Type	P2 (HP) (KW)		Ampere 1~ 230V-50Hz	Flow Rate (Q)										
				l/min	0	5	10	20	30	35	40	45		
				m³/hr	0	0.3	0.6	1.2	1.8	2.1	2.4	2.7		
PER50TR	0.5	0.37	2.5	Head (H)										
				m	37	32	26	16	8	3	-	-	-	-

DIMENSIONS

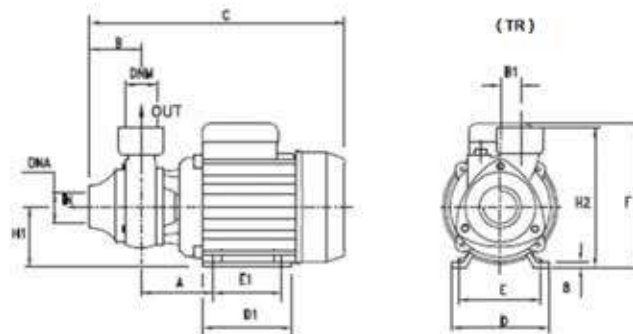

Type	Dimensions												
	A	B	B1	C	D	D1	E	E1	F	H1	H2	DNA	DNM
PER50TR	63	50	20	260	120	101	100	80	158	63	143	1"G	1"G



Self Priming Pumps



SELF-PRIMING Pumps

JET 037 TR →

JET 100 TR →

JET 150-220-
300 TR →



Centrifugal self-priming pump complete of ejector and diffuser for high-priming capability. Suitable for sucking from well up to 9 meter.

MADE IN ITALY

JET 037 TR

DESCRIPTION & APPLICATIONS:

The self-priming TR pumps are designed to pump water even in cases where air is present. As a result of their reliability and the fact that they are easy to use. Suitable for use with clean water and liquids that are not chemically aggressive towards the materials from which the pump is made. they are recommended for use in domestic applications such as the distribution of water in combination with small or medium sized pressure sets. and for the irrigation of gardens and allotments, etc



MAIN FEATURES

Pump has an epoxy electro coating treatment

Flow rate up to 60 l/min

Head up to 32 m

Max water temperature 50 °c

Ambient temperature up to 40 °c

COMPONENT CONSTRUCTION

Pump body	Cast iron G20
Pump bracket	Cast iron G20
Impeller	Brass H59
Diffuser	PPO
Pump shaft	Stainless steel AISI 304
Mechanical seal	Ceramic / Graphite

MOTOR

Two-pole induction motor

External cooling

Insulation class F

Protection degree IP44

Single phase 220V/50Hz

Thermal protection

Continuous service S1



JET 037 TR

SPECIFICATIONS

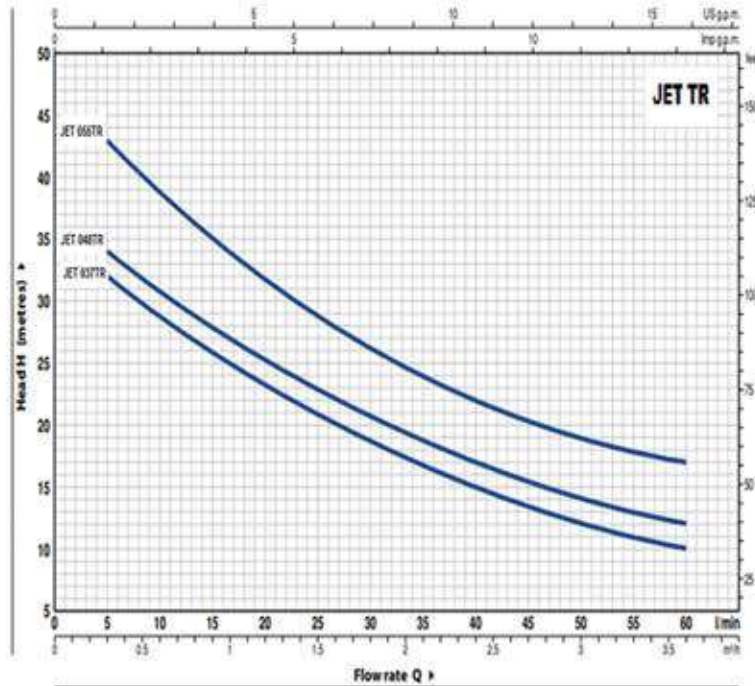

Type	P2 (HP) (KW)		Ampere 1~ 230V- 50Hz	Flow Rate (Q)										
				l/min	0	5	10	20	30	35	40	45	50	60
				m ³ /hr	0	0.3	0.6	1.2	1.8	2.1	2.4	2.7	3.0	3.6
JET037TR	0.5	0.37	2.7	Head (H)										
				m	32	30	28	25	21	19	17	11	8	5

DIMENSIONS

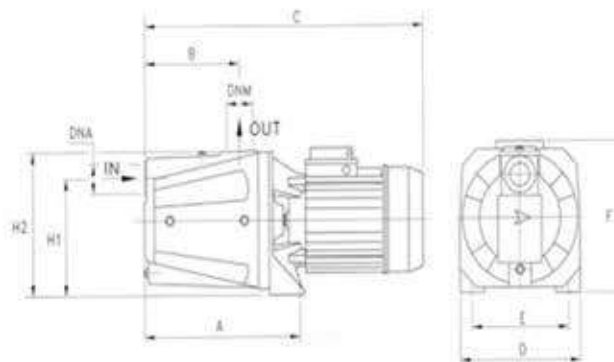

Type	Dimensions									
	A	B	C	D	E	F	H1	H2	DNA	DNM
JET037TR	230	140	395	180	140	195	152	185	1"G	1"G



JET 100 TR

DESCRIPTION & APPLICATIONS:

The self-priming TR pumps are designed to pump water even in cases where air is present. As a result of their reliability and the fact that they are easy to use. Suitable for use with clean water and liquids that are not chemically aggressive towards the materials from which the pump is made. they are recommended for use in domestic applications such as the distribution of water in combination with small or medium sized pressure sets. and for the irrigation of gardens and allotments, etc



MAIN FEATURES

Pump has an epoxy electro coating treatment
Flow rate up to 55 l/min
Head up to 56 m
Max water temperature 50 °c
Ambient temperature up to 40 °c

COMPONENT CONSTRUCTION

Pump body	Cast iron G20
Pump bracket	Cast iron G20
Impeller	Brass H59
Diffuser	PPO
Pump shaft	Stainless steel AISI 304
Mechanical seal	Ceramic / Graphite

MOTOR

Two-pole induction motor
External cooling
Insulation class F
Protection degree IP44
Single phase 220V/50Hz
Thermal protection
Continuous service S1



JET 100 TR

SPECIFICATIONS

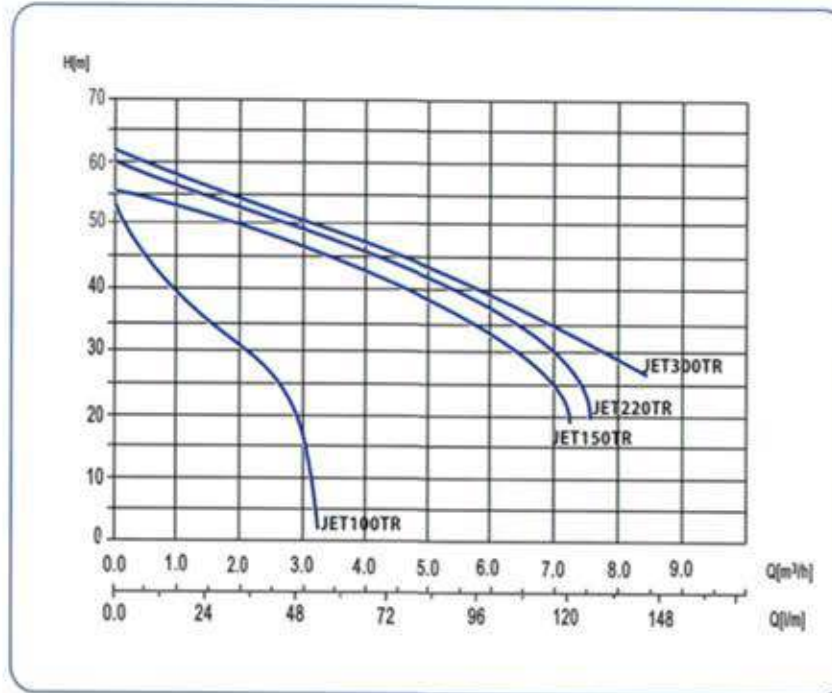

Type	P2		Ampere 1~ 230V- 50Hz	Flow Rate (Q)										
				l/min	0	8	16	25	33	42	50	53	58	66
	(HP)	(KW)	m³/hr	0	0.5	1.0	1.5	2.0	2.5	3.00	3.2	3.5	4.00	
JET100TR	1.0	0.74	4.9	Head (H)										
				m	56	47	38	33	28	20	8	4	-	-

DIMENSIONS

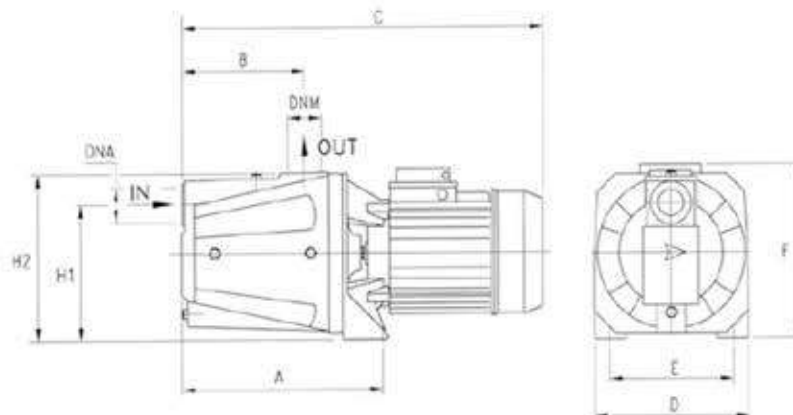

Type	Dimensions									
	A	B	C	D	E	F	H1	H2	DNA	DNM
JET100TR	230	140	420	180	140	195	152	185	1"G	1"G



JET 150/220/300 TR

DESCRIPTION & APPLICATIONS

The self-priming TR pumps are designed to pump water even in cases where air is present. As a result of their reliability and the fact that they are easy to use.

Suitable for use with clean water and liquids that are not chemically aggressive towards the materials from which the pump is made.

they are recommended for use in domestic applications such as the distribution of water in combination with small or medium sized pressure sets. and for the irrigation of gardens and allotments, etc



MAIN FEATURES

Pump has an epoxy electro coating treatment

Flow rate up to 140 l/min

Head up to 62 m

Max water temperature 50 °c

Ambient temperature up to 40 °c

COMPONENT CONSTRUCTION

Pump body	Cast iron G20
Pump bracket	Cast iron G20
Impeller	Brass H59
Diffuser	PPO
Pump shaft	Stainless steel AISI 304
Mechanical seal	Ceramic / Graphite

MOTOR

Two-pole induction motor

External cooling

Insulation class F

Protection degree IP44

Single phase 220V/50Hz

Thermal protection

Continuous service S1



JET 150/220/300 TR

SPECIFICATIONS

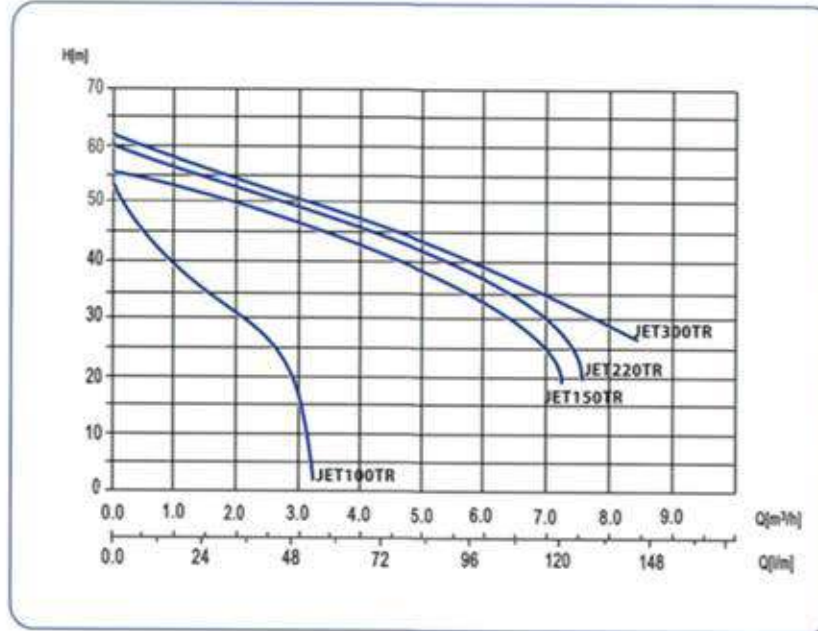

Type	P2		Ampere 1~ 230V-50Hz z	Flow Rate (Q)											
				l/min	0	16	33	50	66	83	100	116	133	150	
	(HP)	(KW)	m³/hr	0	1	2	3	4	5	6	7	8	9		
JET150TR	1.5	1.1	6.7		Head (H)										
JET220TR	2	1.5	7.8		56	53	50	46	42.5	38	33	25	-	-	
JET300TR	3	2.2	8.4		60	57	54	49	45	42	37.5	30	-	-	
				m	62	58	55	50	47	44	39.5	35	29	-	

DIMENSIONS

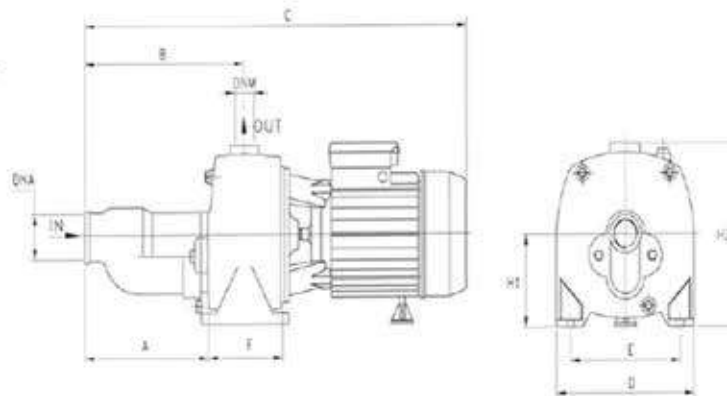

MODEL	Dimensions (mm)									
	A	B	C	D	E	F	H1	H2	DNA	DNM
JET150TR	204	257	596	220	177	105	112	240	G1½"	G1"
JET220TR	204	257	596	220	177	105	112	240	G1½"	G1"
JET300TR	204	257	596	220	177	105	112	240	G1½"	G1"



Monoblock





MONOBLOCK
Pumps

SN-Series →

The Monoblock Pumps introduced by VAMA come with easy installation features, greater efficiency and low maintenance cost.

The compact shape along with the superior quality of the Monoblock Pumps ensure hassle-free service for agricultural, industrial and commercial sectors.

MADE IN ITALY

SN SERIES

DESCRIPTION & APPLICATIONS:

SN series is single impeller centrifugal monoblock electro pumps. This series perform with high water capacity related to good pressure. Use for industrial, civil and agriculture applications and water supplying. Such as fire-fighting, cooling, heating and etc



MAIN FEATURES

Flow rate up to 650 l/min

Head up to 62 m

Max water temperature 50 °c

Ambient temperature up to 40 °c

COMPONENT CONSTRUCTION

Pump body	Cast iron G20
Pump bracket	Cast iron G20
Impeller	Cast iron
Pump shaft	Stainless steel AISI 304
Mechanical seal	Ceramic / Graphite

MOTOR

Two-pole induction motor
External cooling
Insulation class F
Protection degree IP44
three phase 380V/50Hz
Continuous service S1



SN SERIES

SPECIFICATIONS

Model	P2		Ampere			Flow Rate (Q)													
	HP	KW	230 V	400 V	690 V	l/min	100	150	200	250	300	350	400	450	500	550	600	650	
3-50Hz						m ³ /hr	6	9	12	15	18	21	24	27	30	33	36	39	
							Head (H)												
SN 32-160B	4	3	11.6	6.8	-	m	44	42.5	39	35.5	-	-	-	-	-	-	-	-	-
SN 32-160A	5.5	4	16	9.4	-		56.5	54.5	52	48	43	-	-	-	-	-	-	-	-
SN 32-200B	7.5	5.5	-	13	7		52.5	51.5	51	49	47	45.5	43	40.5	38	33.5	29	-	-
SN 32-200A	10	7.5	-	16	9.5		62	61	60	58.5	57	54.5	52	50	47	44	40	-	-
SN 40-160B	4	3	14	8	-		-	30	29.8	29.6	29	28	27	26	24.5	22.7	21	-	-
SN 40-160A	5.5	4	17	10	-		-	35.5	35.4	35.3	35	34.2	33.2	32	30.6	29	27.3	25	-
SN 40-200B	7.5	5.5	-	13	7		-	-	-	47	45.5	44	42	39	35	33	30	-	-
SN 40-200A	10	7.5	-	16	9.5		-	-	-	56	55	54	53	51	49	45	40	-	-

DIMENSIONS

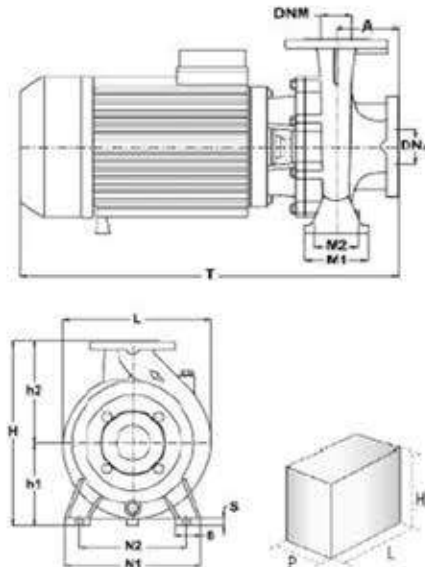

Model	Dimensions (mm)													
	A	H	h1	h2	L	M1	M2	N1	N2	B	S	T	DNA	DNM
SN 32-160B	80	340	160	180	260.5	100	70	240	190	20	14	450	50	32
SN 32-160A	80	340	160	180	260.5	100	70	240	190	50	14	450	50	32
SN 32-200B	80	340	160	180	268	100	70	240	190	50	15	541	50	32
SN 32-200A	80	340	160	180	268	100	70	240	190	50	15	541	50	32
SN 40-160B	80	292	132	160	245.5	100	70	240	190	50	15	460	65	40
SN 40-160A	80	292	132	160	245.5	100	70	240	190	50	15	460	65	40
SN 40-200B	100	340	160	180	275	100	70	265	212	50	15	560	65	40
SN 40-200A	100	340	160	180	275	100	70	265	212	50	15	560	65	40



Satinlessteel Pumps



STAINLESS STEEL Pumps

BLC →

DWK →

DWB →

CA →

Stainless steel pumps. Pumping of clean non-loaded fluids; pressurizing system; irrigation; drinking and glycol water; water treatment; heating and air conditioning; washing system.

MADE IN ITALY

BLC

DESCRIPTION & APPLICATIONS:

BLC series is single-stage stainless steel pump with closed impeller, Hydraulic bulge technology is adopted, sturdy construction; Compact design; efficient spiral-cased pump body design, all components in contact with the pumped liquid are in stainless steel AISI 316 guaranteeing complete hygiene and maximum resistance against corrosion

Use in domestic, agriculture, industrial and food processing. Such as water systems, air condition system, etc



MAIN FEATURES:

Flow rate up to 450 l/min

Head up to 36 m

Max water temperature 70 °c

Ambient temperature up to 40 °c

COMPONENT CONSTRUCTION

Pump body	Stainless steel AISI 316
Pump bracket	Aluminum
Impeller	Stainless steel AISI 316
Pump shaft	Stainless steel AISI 316
Mechanical seal	Graphite / Silicon

MOTOR

Two-pole induction motor
External cooling
Insulation class F
Protection degree IP55
Single phase 220V/50Hz
Thermal protection
Continuous service S1



BLC

SPECIFICATIONS

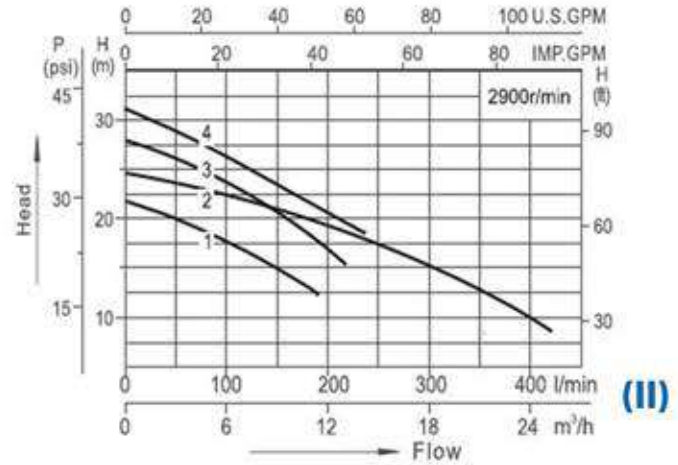
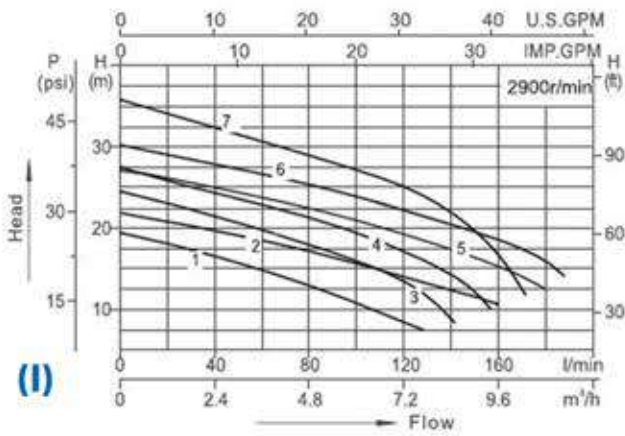

Type	P2		Curve	Ampere 1~230V-50Hz	Flow Rate (Q)												
	(HP)	(KW)			l/min	0	20	40	60	80	100	120	140	160	180	200	
																	m ³ /hr
BLC 70/055	0.75	0.55	1	3.8	Head (H)												
BLC 70/075	1	0.75	3	5.2	19	18	16.5	15	13	11.5	7	-	-	-	-		
BLC 120/110	1.5	1.1	5	7	24.5	23	21.5	20	18	16.5	13	7.5	-	-	-		
BLC 120/150	2	1.5	6	9.2	27	26.5	25	23	22.5	21.5	19	17.5	15	12.5	-		
BLC 200/150	2	1.5	3-II	9.2	30	29	28	26	25	23.5	22	20	18	16	-		
BLC 200/185	2.5	1.85	4-II	13	28	27.5	27	26	24	23.5	22.5	21	20	18.5	17		
					32	31	28.5	28	27	26	25	24	23	22.5	21		

DIMENSIONS

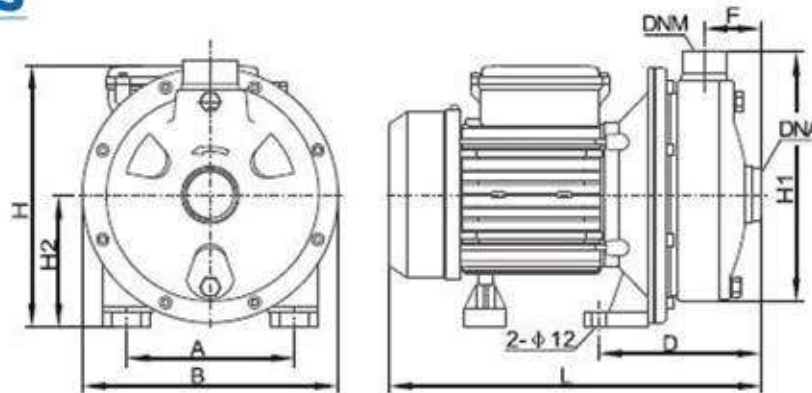

Model	Dimensions (mm)									DNA	DNM
	A	B	C	D	F	L	H	H1	H2		
BLC 70/055	140	213	-	138	49	315	218	232	110	G1¼	G1
BLC 70/075	140	213	-	138	49	315	218	232	110	G1¼	G1
BLC 120/110	140	213	-	138	49	337	230	232	110	G1¼	G1
BLC 120/150	150	234	-	140	46	373	255	240	120	G1¼	G1
BLC 200/150	140	213	-	138	49	366	255	222	110	G1½	G1
BLC 200/185	140	213	-	138	49	354	255	222	110	G1½	G1



DWK

DESCRIPTION & APPLICATIONS:

DWK series is single-stage stainless steel pump with an open impeller, they have the characteristics of large flow, all components in contact with the pumped liquid are in stainless steel AISI 304 this guaranteeing complete hygiene and maximum resistance against corrosion Use in domestic, agriculture, industrial and food processing. Such as convey of solid particles, viscosity liquids, circulation systems and etc



MAIN FEATURES:

Flow rate up to 800 l/min
Head up to 21 m
Max water temperature 104 °c
Ambient temperature up to 40 °c

COMPONENT CONSTRUCTION

Pump body	Stainless steel AISI 304
Pump bracket	Aluminum
Impeller	Stainless steel AISI 304
Pump shaft	Stainless steel AISI 316
Mechanical seal	Graphite / Silicon

MOTOR

Two-pole induction motor
External cooling
Insulation class F
Protection degree IP55
Single phase 220V/50Hz
Thermal protection
Continuous service S1



DWK

SPECIFICATIONS

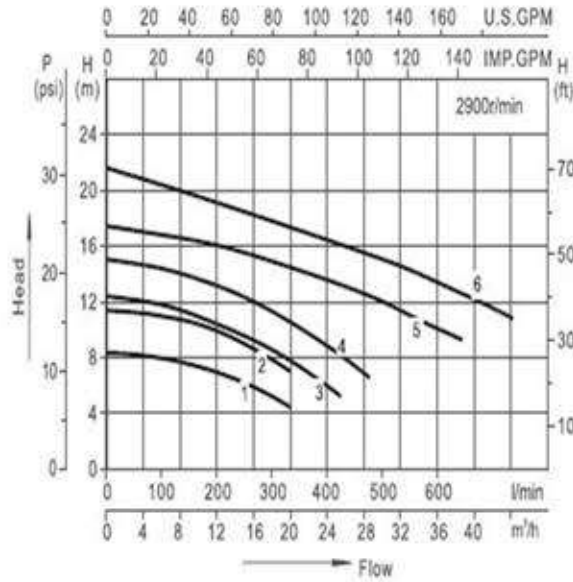

Type	P2		Curve	Ampere 1~ 230V- 50Hz	Flow Rate (Q)											
	(HP)	(KW)			l/min m³/hr	0	100	200	300	400	500	550	600	700	800	
						0	6	12	18	24	30	33	36	42	48	
DWK 150	1.5	1.1	3	7	Head (H)											
DWK 200	2	1.5	4	9.2	m	12	11.5	10	7.5	5	-	-	-	-	-	-
DWK 300	3	2.2	5	14	m	15	14	13	10.5	9	6	-	-	-	-	-
					m	17	16.5	16	15	13.5	11	10.5	10	9	-	-

DIMENSIONS

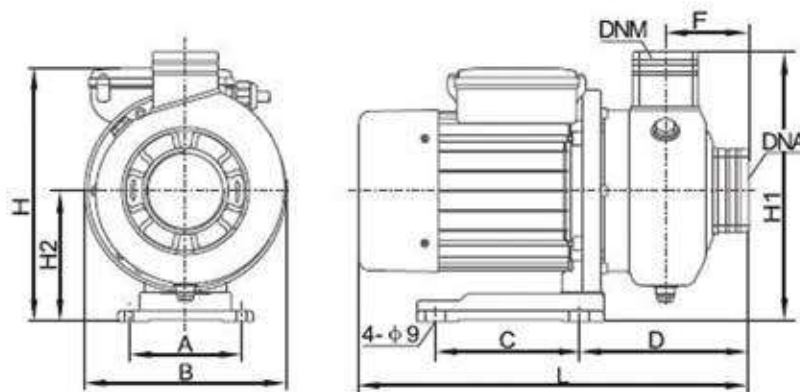

Model	Dimensions (mm)									DNA	DNM
	A	B	C	D	F	L	H	H1	H2		
DWK150	120	172	-	159	75	335	216	234	110	G2	G2
DWK200	108	193	138	165	82	378	243	258	125	G2	G2
DWK300	108	193	138	163	82	413	242	258	125	G2½	G2



DWB

DESCRIPTION & APPLICATIONS:

DWB series is single-stage stainless steel pump with a closed impeller, Hydraulic bulge technology is adopted, sturdy construction; Compact design; efficient spiral-cased pump body design, all components in contact with the pumped liquid are in stainless steel AISI 304 this guaranteeing complete hygiene and maximum resistance against corrosion

*Use in domestic, agriculture, industrial and food processing.
Such as convey a wide range of liquid, air condition system, etc*



MAIN FEATURES:

Flow rate up to 600 l/min

Head up to 29 m

Max water temperature 70 °c

Ambient temperature up to 40 °c

COMPONENT CONSTRUCTION

Pump body	Stainless steel AISI 304
Pump bracket	Aluminum
Impeller	Stainless steel AISI 304
Pump shaft	Stainless steel AISI 316
Mechanical seal	Graphite / Silicon

MOTOR

Two-pole induction motor
External cooling
Insulation class F
Protection degree IP55
Single phase 220V/50Hz
Thermal protection
Continuous service S1



DWB

SPECIFICATIONS

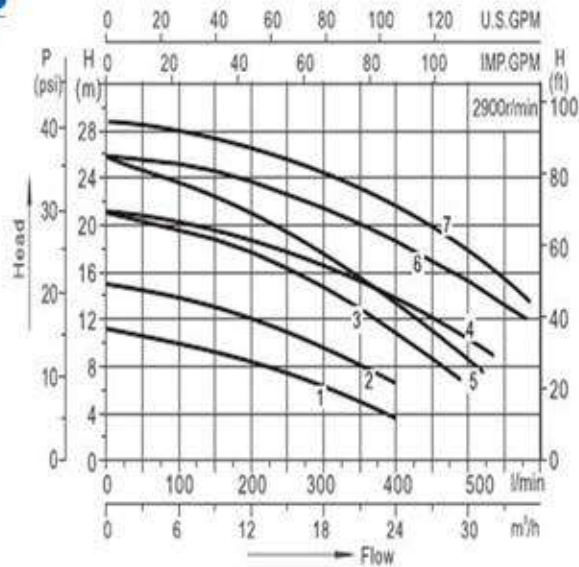

Type	P2		curve	Ampere 1~ 230V- 50Hz	Flow Rate (Q)											
	(HP)	(KW)			l/min		0	100	150	200	250	300	350	400	500	600
					m³/hr	0	6	9	12	15	18	21	24	30	36	
DWB 300/1.1	1.5	1.1	3	6.8	Head (H)											
DWB 300/1.5	2	1.5	5	9.6	m		21	19.5	18.5	17.5	16	14.5	13	10.5	-	-
DWB 500/1.5	2	1.5	4	9.6	m		25	23	22	21	19.5	17	15	13	9	-
DWB 500/2.2	3	2.2	6	14	m		21	20	19.5	18.5	17.5	16	15	13	10	-
					m		25	24	23	22.5	21	20	18.5	17	15	12

DIMENSIONS

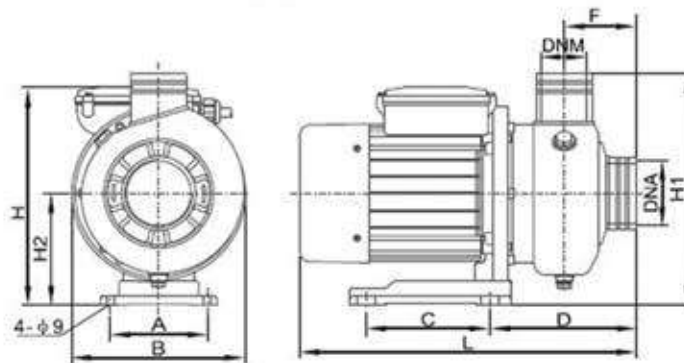

Model	Dimensions (mm)									DNA	DNM
	A	B	C	D	F	L	H	H1	H2		
DWB 300/1.1	108	193	138	165	82	378	243	258	125	G2	G2
DWB 300/1.5	108	193	138	165	82	378	243	258	125	G2	G2
DWB500/1.5	108	193	138	165	82	378	243	258	125	G2	G2
DWB 500/2.2	108	193	138	165	82	415	243	258	125	G2	G2



A delivery person in a blue uniform is handing a cardboard box to a customer. The customer's hands are visible, holding the box. The background is blurred, showing greenery and a white wall.

*At Your
Doorstep.*

 **19301**

CA

DESCRIPTION & APPLICATIONS:

CA series is a horizontal single-stage stainless steel pump with closed impeller, Hydraulic bulge technology is adopted, sturdy construction; Compact design; efficient spiral-cased pump body design, all components in contact with the pumped liquid are in stainless steel AISI 304 or AISI 316 this guaranteeing complete hygiene and maximum resistance against corrosion. Motor can draw out from pump without disassembling the pump casing and pipe line.

Use in domestic, agriculture and industrial. Such as water systems, air condition system, Pressure boosting, Firefighting, heating systems and etc.



MAIN FEATURES:

- Flow rate up to 1100 l/min
- Head up to 68 m
- Max water temperature 70 °c
- Ambient temperature up to 40 °c

COMPONENT CONSTRUCTION

- | | |
|-------------------|--------------------------|
| - Pump body | Stainless steel AISI 304 |
| - Pump bracket | Aluminum |
| - Impeller | Stainless steel AISI 304 |
| - Pump shaft | Stainless steel AISI 316 |
| - Mechanical seal | Graphite / Silicon |

MOTOR

- Two-pole induction motor
- External cooling
- Insulation class F
- Protection degree IP55
- Single phase 220V/50Hz
- Three phase 380V/50Hz
- Thermal protection (for single phase)
- Continuous service S1



CA

SPECIFICATIONS (CA 50-32)

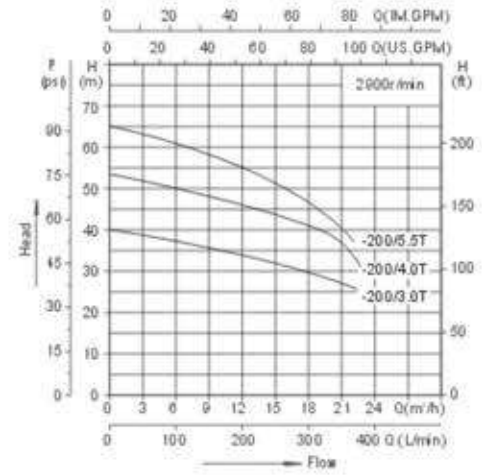
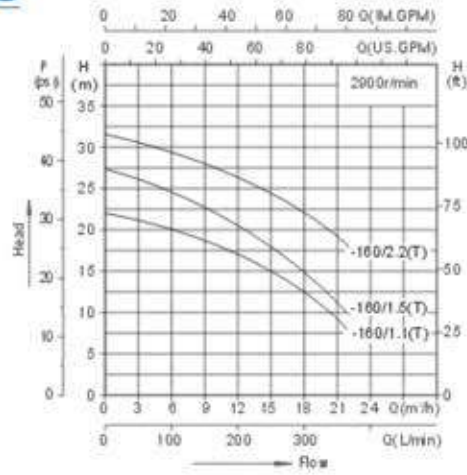

(CA 65-40)

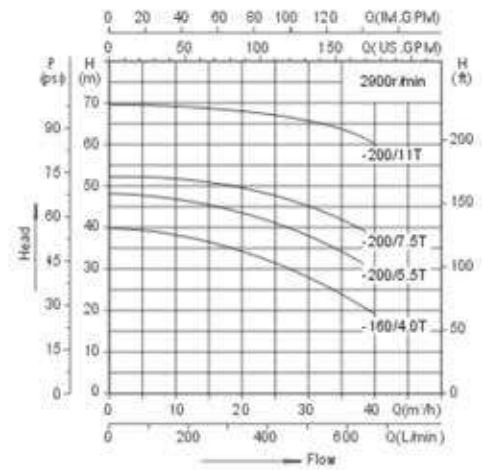
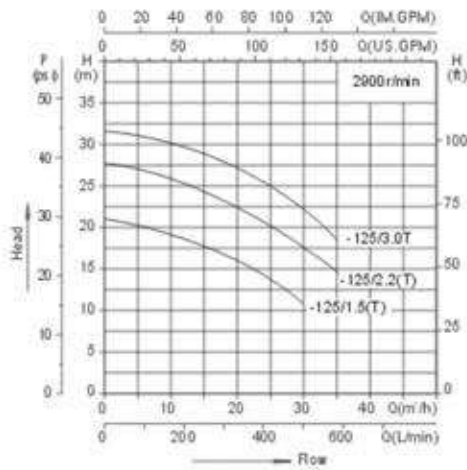

(CA 65-50)

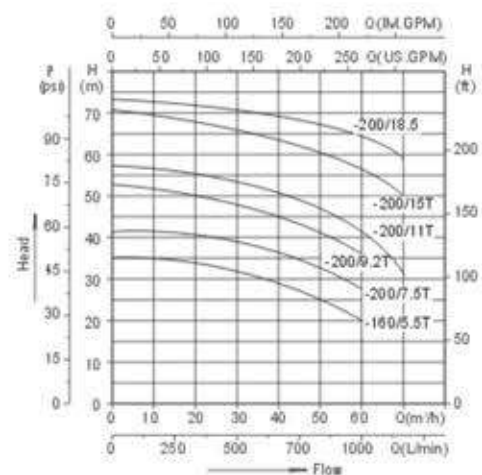
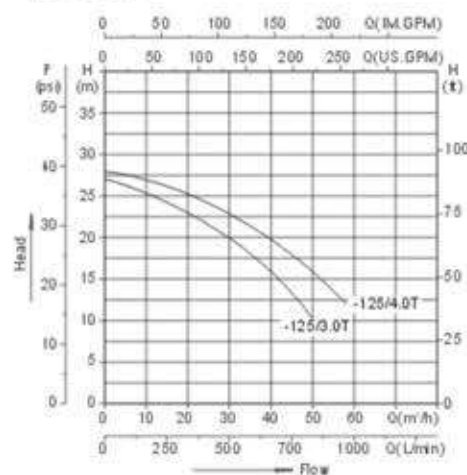

CA

SPECIFICATIONS

Type	P2		Ampere		Flow Rate (Q)								
			1~ 230V-50Hz	3~ 380V-50Hz	l/min	50	100	150	210	250	300	335	365
	(HP)	(KW)			m ³ /hr	3	6	9	12.5	15	18	20	22
CA 50-32-160/1.1	1.5	1.1	4.6	2.7	m	21	20	18.5	16.5	15	12.5	10	8
CA 50-32-160/1.5	2.0	1.5	6.2	3.6		26	24.5	22.5	20	18.5	15	12.5	9.5
CA 50-32-160/2.2	3.0	2.2	8.5	4.9		30.5	29.5	27.5	26	24	22.5	20.5	18
CA 50-32-200/3.0	4.0	3.0	-	6.7		38	37	35	34	32	30	28	26
CA 50-32-200/4.0	5.5	4.0	-	8.2		51.5	50	48	45	43	41	39	30
CA 50-32-200/5.5	7.5	5.5	-	11.1		62	60	58	54	52	47	42	37

Type	P2		Ampere		Flow Rate (Q)								
			1~ 230V-50Hz	3~ 380V-50Hz	l/min	85	165	250	335	415	500	580	675
	(HP)	(KW)			m ³ /hr	5	10	15	20	25	30	35	40
CA 65-40-125/2.2	3	2.2	8.5	4.9	m	27	26	24	22	20	17	14	-
CA 65-40-125/3.0	4.0	3.0	-	6.7		31	30	29	27	25	22	18	-
CA 65-40-160/4.0	5.5	4.0	-	8.2		39	38	36.5	34	31	28	24	19
CA 65-40-200/5.5	7.5	5.5	-	11.1		47	46	45.5	44	41	38	34	30
CA 65-40-200/7.5	10	7.5	-	14.9		52	51.5	51	50	48	45	42	38

Type	P2		Ampere		Flow Rate (Q)								
			3~ 380V-50Hz	3~ 380/660V-50 Hz	l/min	85	165	335	500	675	833	1000	1166
	(HP)	(KW)			m ³ /hr	5	10	20	30	40	50	60	70
CA 65-50-125/4.0	5.5	4.0	8.2	4.7	m	28	26	23	20	16	10	-	-
CA 65-50-160/5.5	7.5	5.5	11.1	6.4		34.5	34.5	34	31.5	28.5	24	20	-
CA 65-50-200/7.5	10.0	7.5	14.9	8.6		41	41	40.5	39	36	32	27.5	-



CA

DIMENSIONS

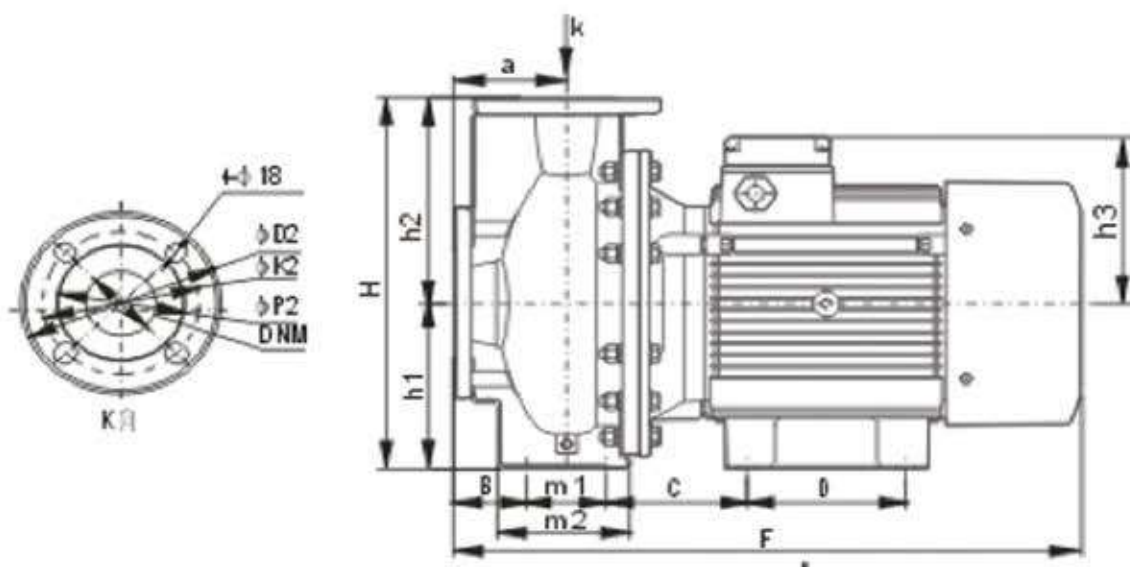

Model	P2 (KW)	φE	F	h	h1	h2	h3	a	m1	m2	n1	n2	B
CA 50-32-160/1.1	1.1	210	395	255	112	143	134	80	70	115	160	190	45
CA 50-32-160/1.5	1.5	210	395	255	112	143	134	80	70	115	160	190	45
CA 50-32-160/2.2	2.2	210	428	255	112	143	119	80	70	115	160	190	45
CA 50-32-200/3.0	3.0	300	460	340	160	180	119	80	70	118	190	240	45
CA 50-32-200/4.0	4.0	300	498	340	160	180	142	80	70	118	190	240	45
CA 50-32-200/5.5	5.5	300	532	340	160	180	162	80	70	118	190	240	45
CA 65-40-125/2.2	2.2	210	425	255	112	143	119	80	70	115	160	190	45
CA 65-40-125/3.0	3.0	250	460	292	132	160	119	80	70	118	190	240	45
CA 65-40-160/4.0	4.0	250	498	292	132	160	142	80	70	118	190	240	45
CA 65-40-200/5.5	5.5	300	554	360	160	200	162	100	70	118	212	264	65
CA 65-40-200/7.5	7.5	300	592	360	160	200	162	100	70	118	212	264	65
CA 65-50-125/4.0	4.0	250	498	292	132	160	142	80	70	115	190	240	45
CA 65-50-160/5.5	5.5	300	554	360	160	200	162	100	70	118	212	264	65
CA 65-50-200/7.5	7.5	300	592	360	160	200	162	100	70	118	212	264	65



CA

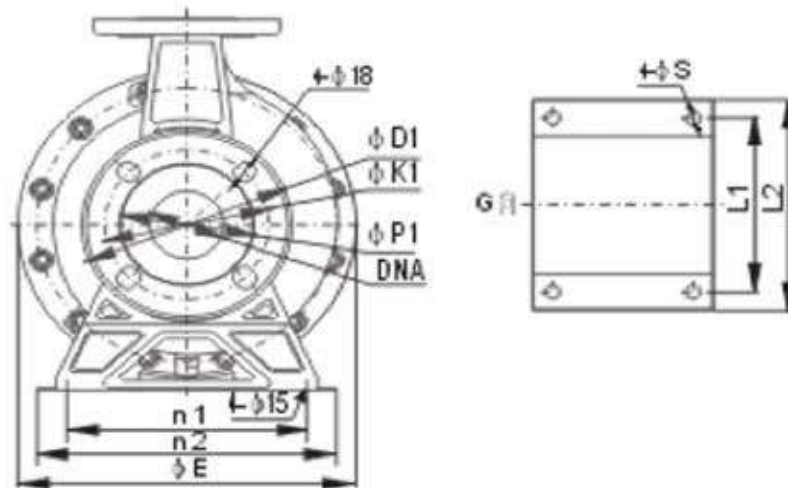

c	D	ϕS	L1	L2	$\phi D1$	$\phi K1$	$\phi P1$	$\phi D2$	$\phi K2$	$\phi P2$	DNA	DNM
95	90	12	125	155	165	125	96	140	100	76	50	32
95	90	12	125	155	165	125	96	140	100	76	50	32
111	100	12	160	190	165	125	96	140	100	76	50	32
111	100	12	160	190	165	125	96	140	100	76	50	32
114	140	15	190	225	165	125	96	140	100	76	50	32
122	140	15	190	230	165	125	96	140	100	76	50	32
111	100	12	160	190	185	145	115	150	110	80	65	40
111	100	12	160	190	185	145	115	150	110	80	65	40
114	140	15	190	225	185	145	115	150	110	80	65	40
124	140	15	190	230	185	145	115	150	110	80	65	40
124	140	15	190	230	185	145	115	150	110	80	65	40
114	140	15	190	225	185	145	115	165	125	96	65	50
124	140	15	190	230	185	145	115	165	125	96	65	50
124	140	15	190	230	185	145	115	165	125	96	65	50



Multistage





Multistage Pumps

CVF-Type →

Vertical Multistage centrifugal pumps. Ideal for non-loaded fluid pumping; pressurization systems; irrigation; drinking or glycol water; water treatment; food industry; heating and air conditioning; washing systems.

MADE IN ITALY

CVF TYPE

DESCRIPTION & APPLICATIONS:

CVF series is applied to slightly corrosive medium due to flow passage parts made of stainless steel after process of pressing and welding. Compact structure, small size, low noise, and easy for maintenance.

Use in domestic, agriculture, industrial and irrigation. Such as water filter and transport in water networks, boosting of main pipeline, boosting in high-rise buildings, air conditioning, boiler water system and etc.

MAIN FEATURES:

- Flow rate up to 100 m³/hr
- Head up to 300 m
- Max water temperature 90 °c
- Ambient temperature up to 40 °c

COMPONENT CONSTRUCTION

- | | |
|---|------------------------------------|
| - Pump body | Stainless steel AISI 304 |
| - Pump bracket | cast iron |
| - Diffuser | Stainless steel AISI 304 |
| - Impeller | Stainless steel AISI 304 |
| - Pump shaft | Stainless steel AISI 431 |
| - Mechanical seal | Tungsten carbide / Silicon carbide |
| - (Cartridge type for easy maintenance) | |

MOTOR

- Full-enclosed and ventilating two-pole standard motor
- Insulation class F
- Protection degree IP55
- Single phase 220V/50Hz
- Three phase 380V/50Hz
- Thermal protection (for single phase)
- Continuous service S1



CVF TYPE

Performance Range

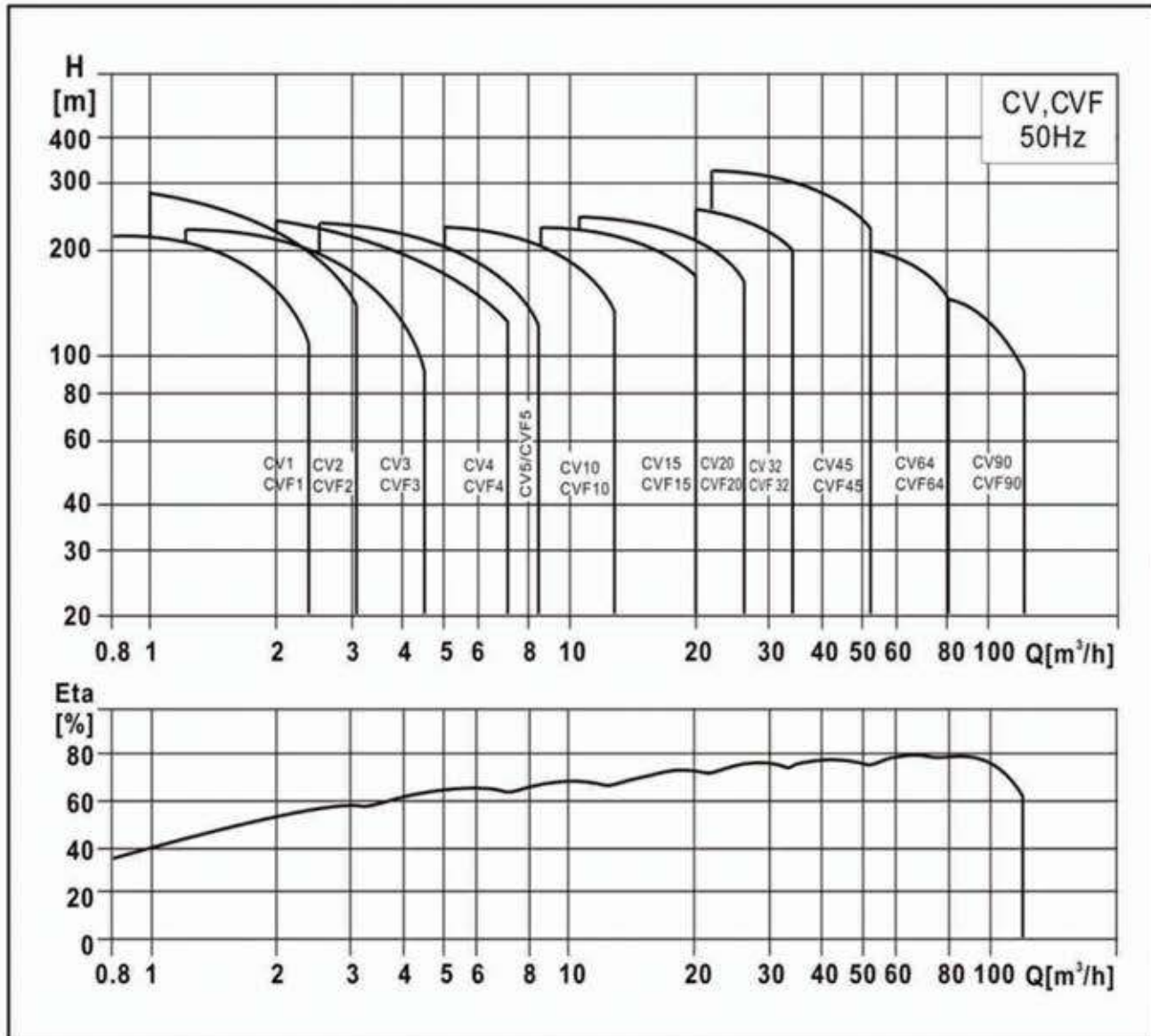

CVF1

SPECIFICATIONS

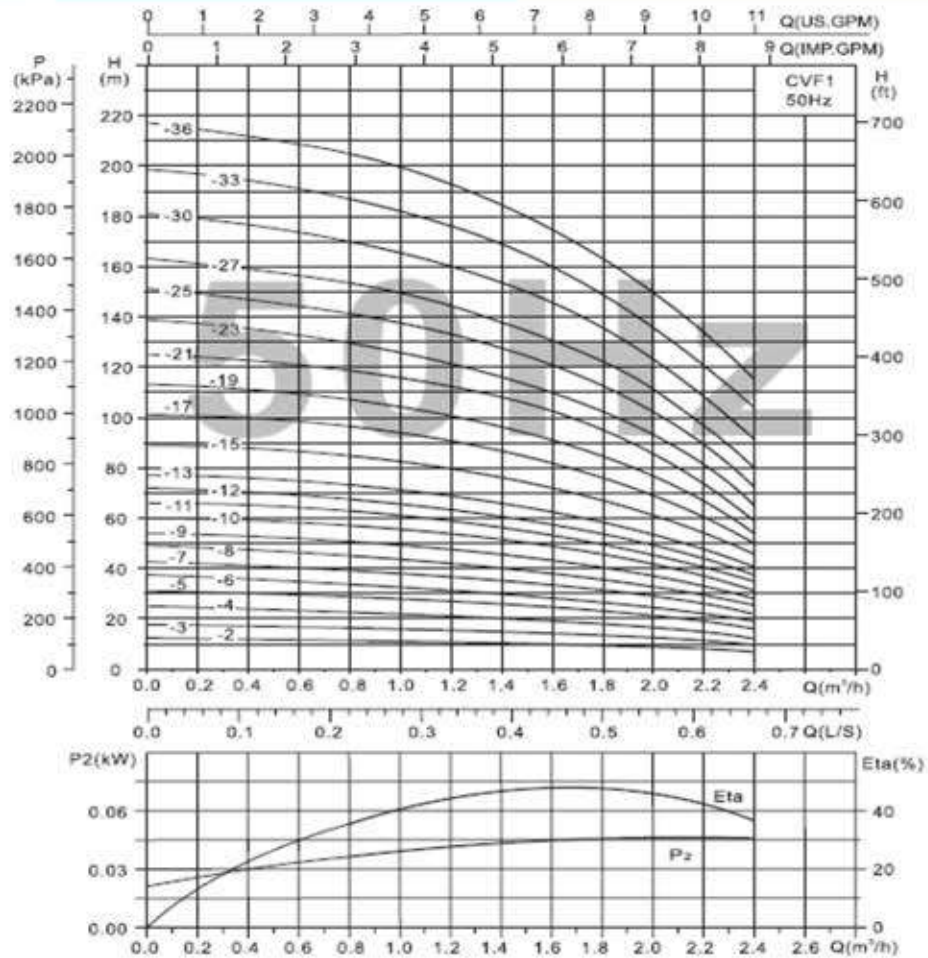

Type	P2		Flow Rate (Q)												
	(HP)	(KW)	m³/hr	0.4	0.6	0.8	1.0	1.2	1.4	1.6	1.8	2.0	2.2		
				Head (H)											
CVF1-2	0.5	0.37	m	12	11.8	11.5	11	11	10.5	9.8	9.2	8.5	7.8		
CVF1-3	0.5	0.37		17.5	17	16.8	16.5	16	15.5	14	13.5	12	10.5		
CVF1-4	0.5	0.37		23.5	23	22.5	22	21	20.5	18.5	18	16.5	14		
CVF1-5	0.5	0.37		29	28.5	28	27.5	26.5	26	24	23	20.5	17.5		
CVF1-6	0.5	0.37		35	34.5	34	33	32	31	28	27	25	22		
CVF1-7	0.5	0.37		41	40	39	38.5	37	35	33	32	29	25		
CVF1-8	0.75	0.55		46.5	46	45.5	44	42	40	38	36	33	29		
CVF1-9	0.75	0.55		52	51.5	51	49.5	47.5	46	44	41	37	34		
CVF1-10	0.75	0.55		58	57.5	57	56	54	52	48	46	41.5	37		
CVF1-11	0.75	0.55		65	63	62.5	61	59	56	54	50	46	40		
CVF1-12	1.0	0.75		70	69	68	66	64	62	58	55	49	43		
CVF1-13	1.0	0.75		75	74.5	74	72	69	66	63	59	54	47		
CVF1-15	1.0	0.75		87	86	85	84	80.5	77	72	68	62	53		
CVF1-17	1.5	1.1		99	97.5	97	95	91	87	81.5	77	69	59		
CVF1-19	1.5	1.1		110.5	109	108	106	101	97	91	86	78	66		
CVF1-21	1.5	1.1		122	120.5	119.5	116	112	108	101	95	86	73		
CVF1-23	1.5	1.1		135	132.5	130	126	122	117	111	104	94	80		
CVF1-25	2.0	1.5		147	144	141	138	133	128	121	114	103	87		
CVF1-27	2.0	1.5		158	156	154	150	144	138	130	121	112	96		
CVF1-30	2.0	1.5		175	173	171	166	160	154	145	136	124	108		
CVF1-33	3.0	2.2		193	191	188	183	176	170	160	150	136	120		
CVF1-36	3.0	2.2		212	209	205	200	192	184	174	164	150	133		



CVF1

DIMENSIONS

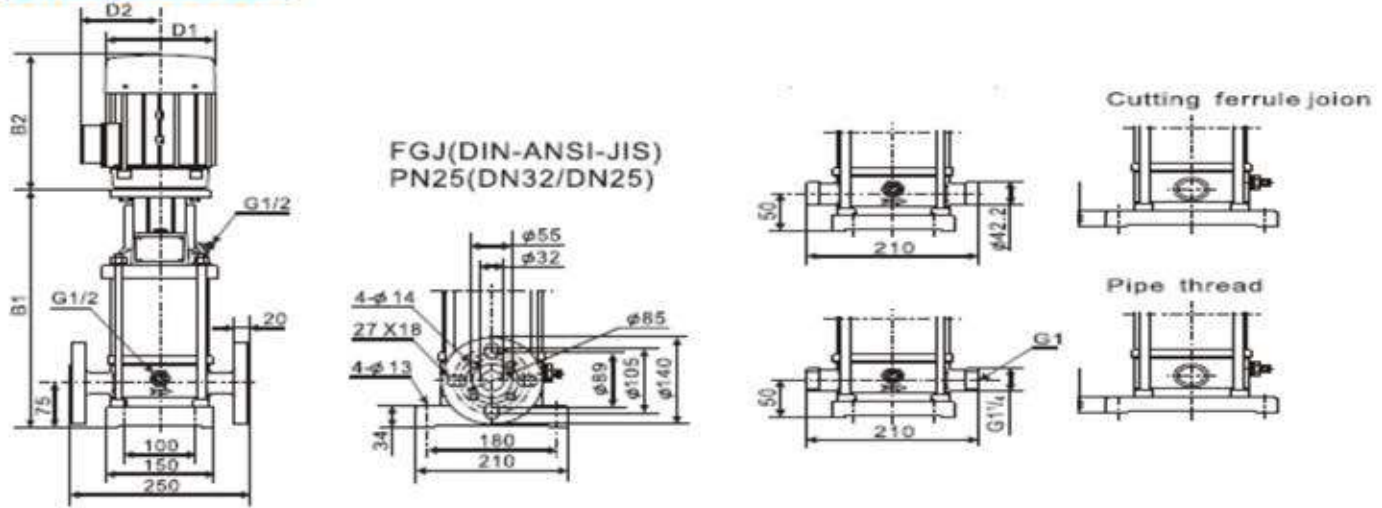

Model	Dimensions (mm)				
	B1	B2	B1+B2	D1	D2
CVF1-2	259	205	464	133	102/124
CVF1-3	277	205	482	133	102/124
CVF1-4	295	205	500	133	102/124
CVF1-5	313	205	518	133	102/124
CVF1-6	331	205	536	133	102/124
CVF1-7	349	205	554	133	102/124
CVF1-8	367	205	572	133	102/124
CVF1-9	385	205	590	133	102/124
CVF1-10	403	205	608	133	102/124
CVF1-11	427	205	632	154	102/124
CVF1-12	439	205	644	154	102/124
CVF1-13	457	205	662	154	102/124
CVF1-15	493	205	698	154	102/124
CVF1-17	535	245	776	154	102/133
CVF1-19	574	245	815	154	111/133
CVF1-21	607	245	848	154	111/133
CVF1-23	643	245	884	154	111/133
CVF1-25	671/687	245/300	919/987	154/177	111/144.5
CVF1-27	715/723	245/300	956/1016	154/177	111/144.5
CVF1-30	769/777	245/300	1010/1070	154/177	111/144.5
CVF1-33	831	245/300	1106/1124	177	116/144.5
CVF1-36	885	245/300	1160/1178	177	116/144.5



CVF2

SPECIFICATIONS

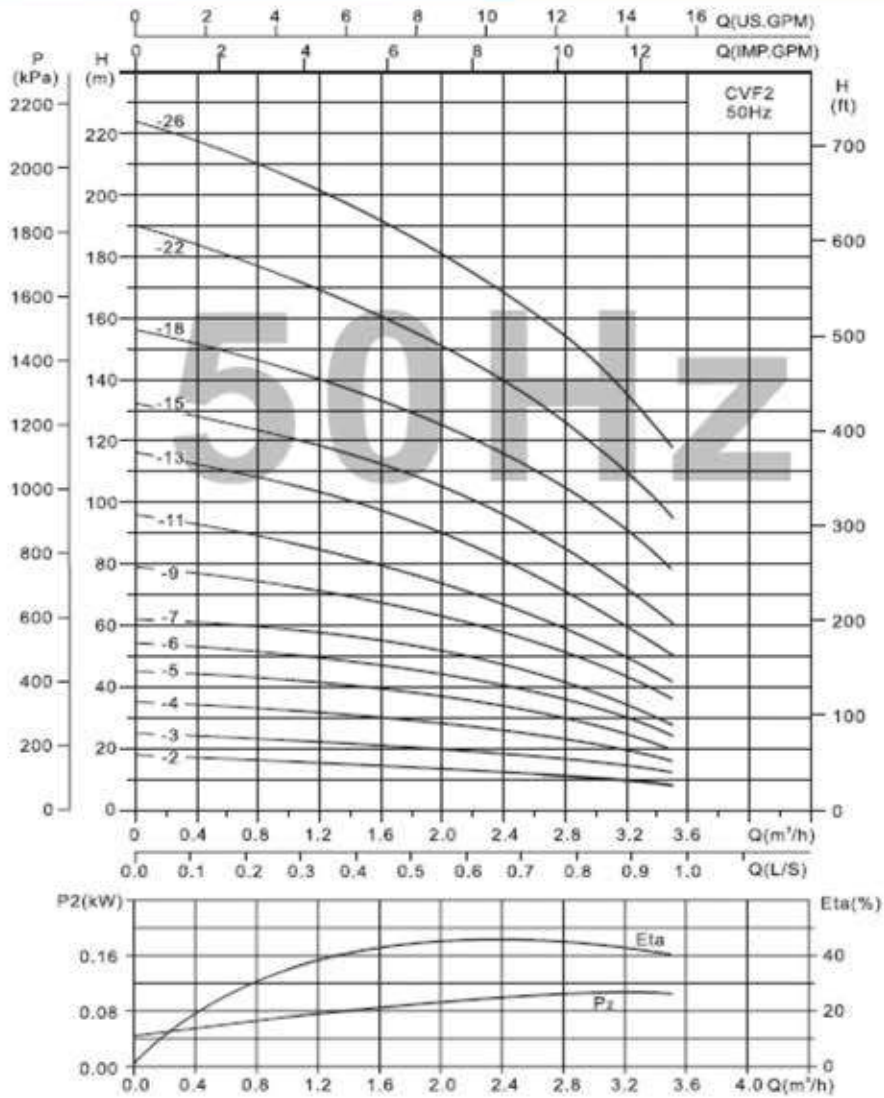

Type	P2		Flow Rate (Q)								
	(HP)	(KW)	m³/hr	1	1.2	1.6	2.0	2.4	2.8	3.2	3.5
				Head (H)							
CVF2-2	0.5	0.37	m	16	15.5	14.5	14	12.5	11	9.5	8
CVF2-3	0.5	0.37		23	22.5	21	20	18.5	16	14	12
CVF2-4	0.75	0.55		32	31	30	28	26	23	20	16
CVF2-5	0.75	0.55		42.5	42	40	37	34.5	30	25	20
CVF2-6	1.0	0.75		51	50	47	44	41	36	30	24
CVF2-7	1.0	0.75		59	57	55	52	47	41	35	28
CVF2-9	1.5	1.1		72	71	67	63	58	51	44	36
CVF2-11	1.5	1.1		87	85	80	74	67	59	50	42
CVF2-13	2.0	1.5		106	104	99	90	81	71	60	51
CVF2-15	2.0	1.5		121	119	112	105	96	85	72	61
CVF2-18	3.0	2.2		143	139	133	125	116	105	91	78
CVF2-22	3.0	2.2		173	169	162	152	140	126	110	95
CVF2-26	4.0	3.0		206	201	191	180	170	155	133	118



CVF2

DIMENSIONS

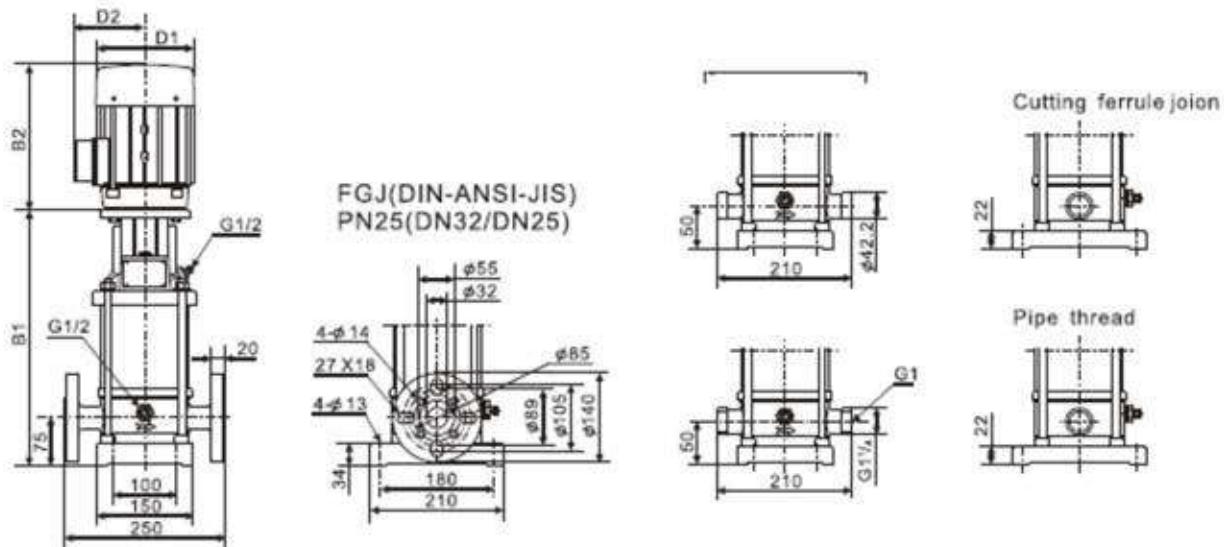

Model	Dimensions (mm)				
	B1	B2	B1+B2	D1	D2
CVF2-2	259	205	464	133	102/124
CVF2-3	277	205	482	133	102/124
CVF2-4	295	205	500	133	102/124
CVF2-5	313	205	518	133	102/124
CVF2-6	331	205	536	133	102/124
CVF2-7	349	205	554	133	102/124
CVF2-9	391	241	632	154	111/133
CVF2-11	427	241	668	154	111/133
CVF2-13	463	241/293	704/758	154/177	111/144.5
CVF2-15	499	241/293	740/792	154/177	111/144.5
CVF2-18	565	275/293	840/858	177	116/144.5
CVF2-22	637	275/293	912	177	116/144.5
CVF2-26	709	293	1002	177	116



CVF3

SPECIFICATIONS

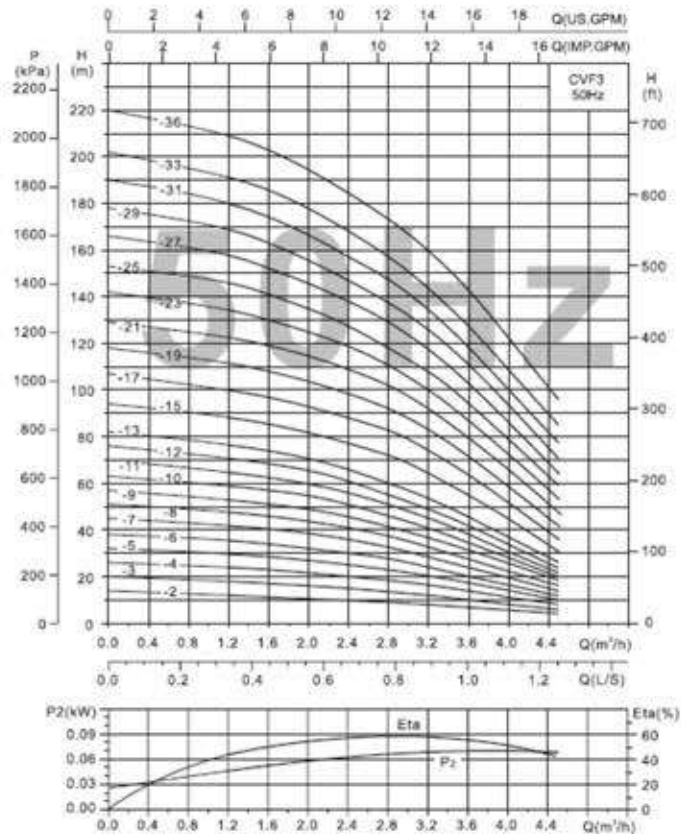

Type	P2		Flow Rate (Q)											
	(HP)	(KW)	m³/hr	1.2	1.6	2.0	2.4	2.8	3.0	3.2	3.4	3.6	4.0	
				Head (H)										
CVF3-2	0.5	0.37	m	12	11.3	10.5	10	9	8.5	8	7.5	7	6	
CVF3-3	0.5	0.37		18	17	16	15	14	13	12	11	10	8	
CVF3-4	0.5	0.37		24	23	21.5	20	18.5	17.5	16.5	15	13.5	11	
CVF3-5	0.5	0.37		30	28.5	27	25	23	22	20.5	19	17.5	14	
CVF3-6	0.75	0.55		36	34	32	30	28	26	24	22	20	16.5	
CVF3-7	0.75	0.55		42	40.5	39	36	33	30.5	28.5	26	24	19.5	
CVF3-8	1.0	0.75		48	46	44	41	37	35	32.5	30	27	22.5	
CVF3-9	1.0	0.75		53	51	49	46	41.5	39	37	34	32	26	
CVF3-10	1.0	0.75		59	57	55	51	46	43	41	37	34	28	
CVF3-11	1.5	1.1		65	62.5	60	56	51	48	45	42	38	30.5	
CVF3-12	1.5	1.1		71	68	66	61	55	52	49	45.5	42	34	
CVF3-13	1.5	1.1		77	74	71	66	60	57	53	50	46	37	
CVF3-15	1.5	1.1		88	85	82	77	72	68.5	64	60	55	44	
CVF3-17	2.0	1.5		100	97	93	88	83	79	74	69	64	52	
CVF3-19	2.0	1.5		112	108	104	98	92	88	83	77	71	58	
CVF3-21	3.0	2.2		123	119	115	108	102	94	92	86	79	65	
CVF3-23	3.0	2.2		134	130	125	119	110	105	100	94	86	72	
CVF3-25	3.0	2.2		146	141	135	128	118	113	108	102	94	79	
CVF3-27	3.0	2.2	158	152	146	138	129	123	117	110	103	86		
CVF3-29	3.0	2.2	169	163	156	147	137	132	125	118	111	93		
CVF3-31	4.0	3.0	180	174	167	157	147	141	134	126	118	100		
CVF3-33	4.0	3.0	191	186	178	168	157	150	143	135	127	108		
CVF3-36	4.0	3.0	209	203	194	184	173	166	159	151	143	122		



CVF3

DIMENSIONS

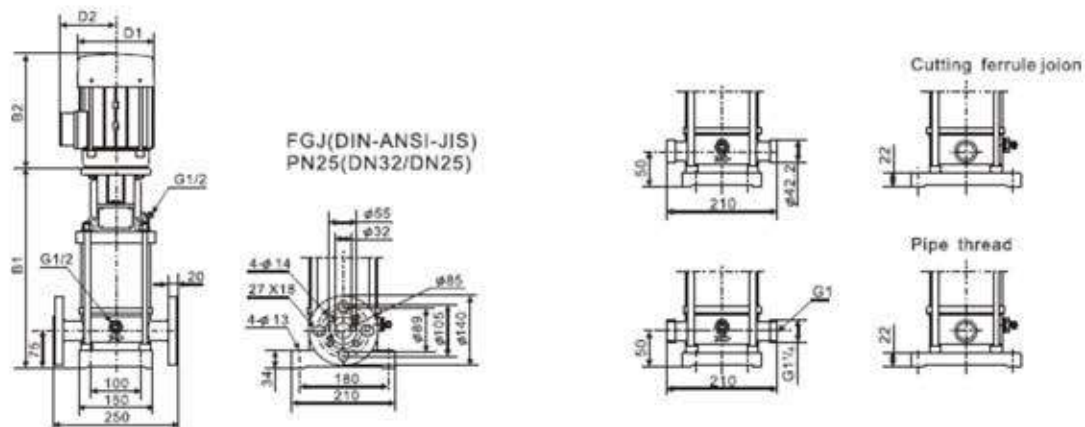

Model	Dimensions (mm)				
	B1	B2	B1+B2	D1	D2
CVF3-2	259	205	464	133	102
CVF3-3	277	205	482	133	102
CVF3-4	295	205	500	133	102
CVF3-5	313	205	518	133	102
CVF3-6	331	205	536	133	102
CVF3-7	349	205	554	133	102
CVF3-8	367	205	572	133	102
CVF3-9	385	205	590	133	102
CVF3-10	403	205	608	133	102
CVF3-11	427	241	668	154	111
CVF3-12	445	241	686	154	111
CVF3-13	463	241	704	154	111
CVF3-15	499	241	740	154	111
CVF3-17	535	241/293	776/828	154	111
CVF3-19	571	241/293	812/864	154	111
CVF3-21	615	275/293	890/908	177	116
CVF3-23	651	275/293	926/944	177	116
CVF3-25	687	275/293	962/980	177	116
CVF3-27	723	275/293	998/1016	177	116
CVF3-29	759	275/293	1034/1052	177	116
CVF3-31	795	275/293	1070/1080	177	116
CVF3-33	831	275/293	1106/1124	177	116
CVF3-36	885	275/293	1160/1178	177	116



CVF4

SPECIFICATIONS

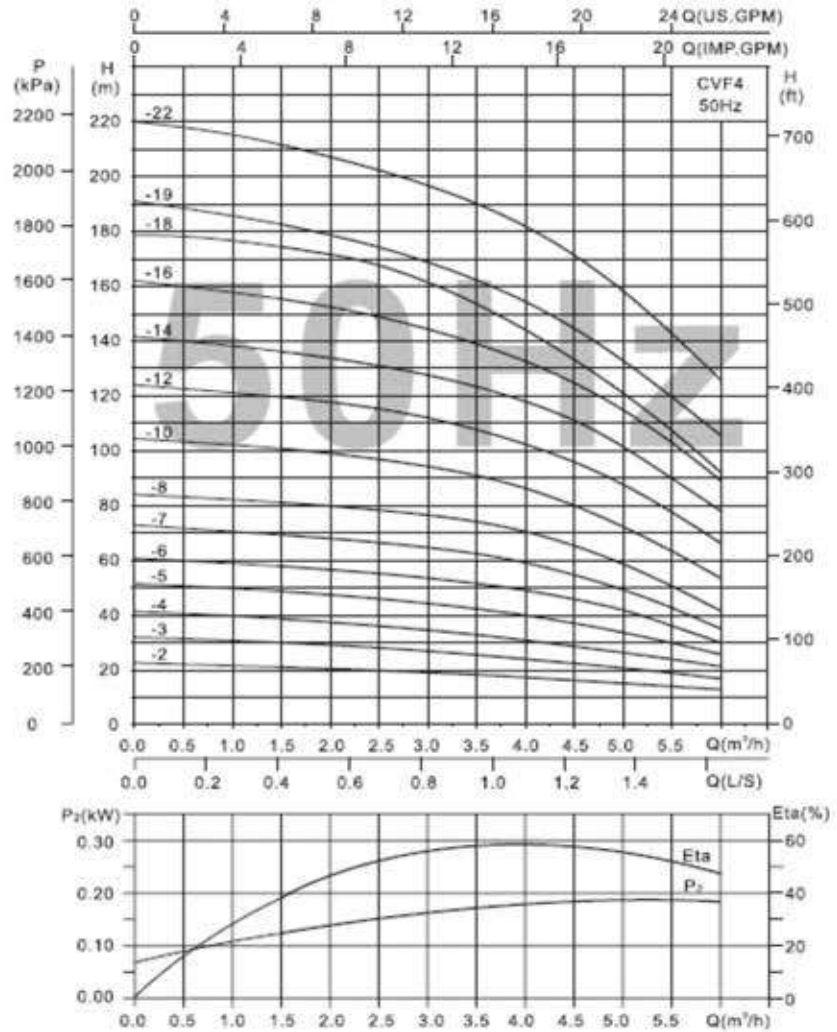

Type	P2		Flow Rate (Q)								
	(HP)	(KW)	m³/hr	1.0	2.0	3.0	4.0	4.5	5.0	5.5	6.0
				Head (H)							
CVF4-2	0.5	0.37	m	22	21	19.5	18	17	16	14	13
CVF4-3	0.75	0.55		31	29.5	28	24	22	21	19	18
CVF4-4	1.0	0.75		40	38	35	31	29	27	24	22
CVF4-5	1.5	1.1		50	48	44	40	38	34	30	26
CVF4-6	1.5	1.1		59	57	53	49	45	41	36	30
CVF4-7	2.0	1.5		71	69	65	59	55	50	43	36
CVF4-8	2.0	1.5		83	80	78	71	65	59	51	42
CVF4-10	3.0	2.2		103	100	95	87	80	79	73	54
CVF4-12	3.0	2.2		122	119	113	103	96	88	78	68
CVF4-14	4.0	3.0		139	134	128	118	111	102	90	79
CVF4-16	4.0	3.0		158	153	145	134	126	116	103	89
CVF4-18	5.5	4.0		176	173	164	148	135	118	108	94
CVF4-19	5.5	4.0		186	180	170	155	145	133	117	98
CVF4-22	5.5	4.0		216	208	197	182	172	159	143	126



CVF4

DIMENSIONS

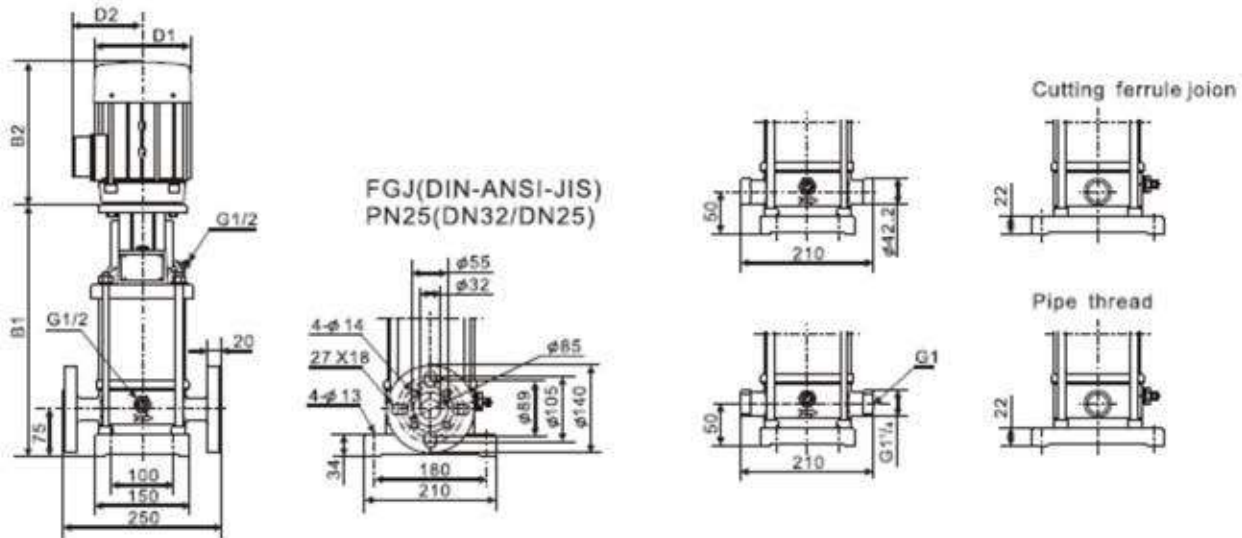

Model	Dimensions (mm)				
	B1	B2	B1+B2	D1	D2
CVF4-2	259	205	464	133	102
CVF4-3	277	205	482	133	102
CVF4-4	295	205	500	133	102
CVF4-5	319	241	560	154	111
CVF4-6	337	241	578	154	111
CVF4-7	355	241/293	596/648	154	111
CVF4-8	373	241/293	614/666	154	111
CVF4-10	417	275/293	692/710	170	117
CVF4-12	453	275/293	728/746	170	117
CVF4-14	489	275/293	764/782	170	117
CVF4-16	525	275/293	800/818	170	117
CVF4-18	581	323	904	200	142
CVF4-19	599	323	922	200	142
CVF4-22	653	323	976	200	142



CVF5

SPECIFICATIONS

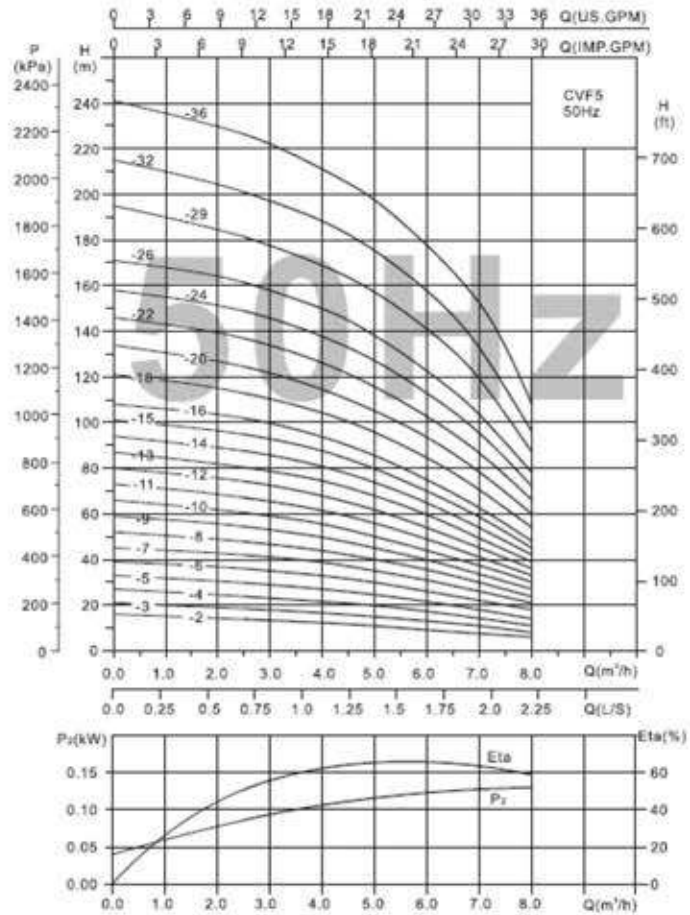

Type	P2		Flow Rate (Q)													
	(HP)	(KW)	m³/hr	2	3	4.0	4.5	5	5.5	6	6.5	7.0	7.5	8.0		
				Head (H)												
CVF5-2	0.5	0.37	m	14	13	12	11.5	11	10	9	8	7.5	6.5	6		
CVF5-3	0.5	0.55		19	18	16.5	15.5	15	14	13	12	11	9	8		
CVF5-4	0.5	0.55		24.5	23	22.5	21	20	18.5	17	15.5	14	12.5	11		
CVF5-5	1.0	0.75		30.5	29	27	26	24.5	23	21.5	20	17.5	16	14		
CVF5-6	1.5	1.1		37	35	33	31.5	30	28	26	24	22	20	18		
CVF5-7	1.5	1.1		43	41	39	37	35	33	31	28	26	24	21		
CVF5-8	1.5	1.1		49	47	44	42	40	38	36	32	30	27	24		
CVF5-9	2.0	1.5		56	53	50	47.5	45	42.5	40	37	33.5	30.5	27		
CVF5-10	2.0	1.5		62	59	55	53	50	47	44	41	37	34	30		
CVF5-11	3.0	2.2		68.5	65.5	61.5	59	56	52	49	45	41	37	33		
CVF5-12	3.0	2.2		75	72.5	68	65	62	58	54	49	45	40.5	36		
CVF5-13	3.0	2.2		81.5	79	74	71	68	64	59.5	54	49	44	39		
CVF5-14	3.0	2.2		89	85	81	77	74	69	65	59	54	48	42		
CVF5-15	3.0	2.2		96	93	88	84	80	75	70	64	59	52	45		
CVF5-16	3.0	2.2		103	100	94	90	85	80	75	69	63	56	48		
CVF5-18	4.0	3.0		115	110	104	100	96	90	85	78	71	63	54		
CVF5-20	4.0	3.0		129	122	115	109	105	99	94	86	78	70	60		
CVF5-22	5.0	4.0		139	134	126	121	116	110	103	95	87	77	66		
CVF5-24	5.0	4.0		152	146	138	133	127	120	113	105	96	84	72		
CVF5-26	5.0	4.0		164	158	150	144	138	131	122	114	104	91	78		
CVF5-29	5.0	4.0	185	177	168	164	157	150	141	132	119	103	87			
CVF5-32	7.5	5.5	205	197	189	183	176	166	158	147	134	114	96			
CVF5-36	7.5	5.5	230	222	212	205	198	188	177	166	154	133	108			



CVF5

DIMENSIONS

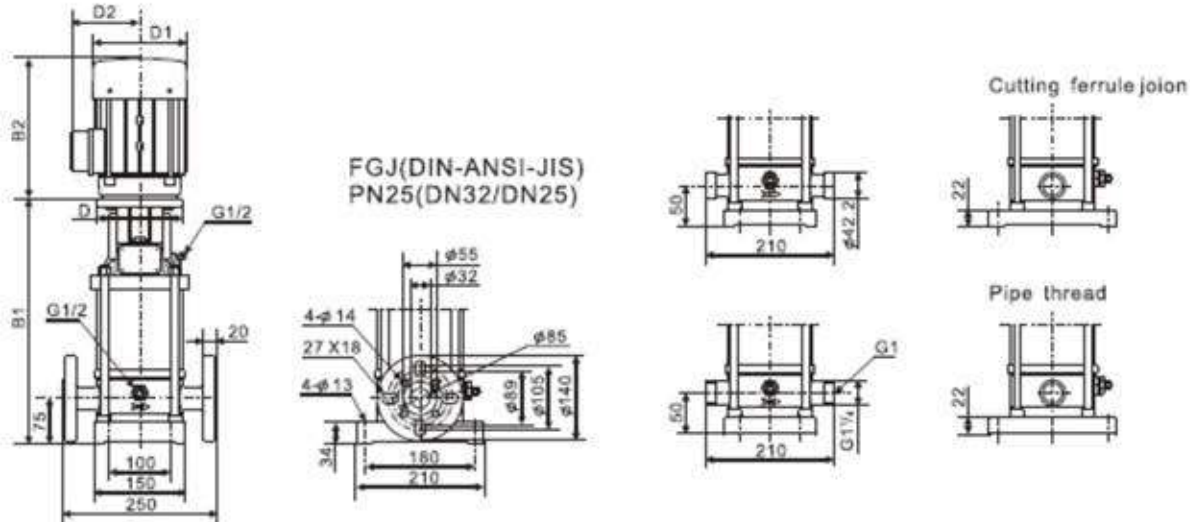

Model	Dimensions (mm)					
	B1	B2	B1+B2	D	D1	D2
CVF5-2	277	205	482	-	133	102
CVF5-3	304	205	509	-	133	102
CVF5-4	331	205	536	-	133	102
CVF5-5	358	205	563	-	133	102
CVF5-6	391	241	632	-	154	111
CVF5-7	418	241	659	-	154	111
CVF5-8	445	241	686	-	154	111
CVF5-9	472	241/293	713/765	-	154	111
CVF5-10	499	241/293	740/790	-	154	111
CVF5-11	534	275/293	809/827	-	177	116
CVF5-12	561	275/293	836/854	-	177	116
CVF5-13	588	275/293	863/881	-	177	116
CVF5-14	615	275/293	890/908	-	177	116
CVF5-15	642	275/293	917/935	-	177	116
CVF5-16	669	275/293	944/962	-	177	116
CVF5-18	723	293	982	-	177	116
CVF5-20	777	293	1052	-	177	116
CVF5-22	851	305	1156	-	197	148
CVF5-24	905	305	1210	-	197	148
CVF5-26	959	305	1264	-	197	148
CVF5-29	1040	305	1345	-	197	148
CVF5-32	1146	390	1536	300	275	210
CVF5-36	1254	390	1644	300	275	210



CVF15

SPECIFICATIONS

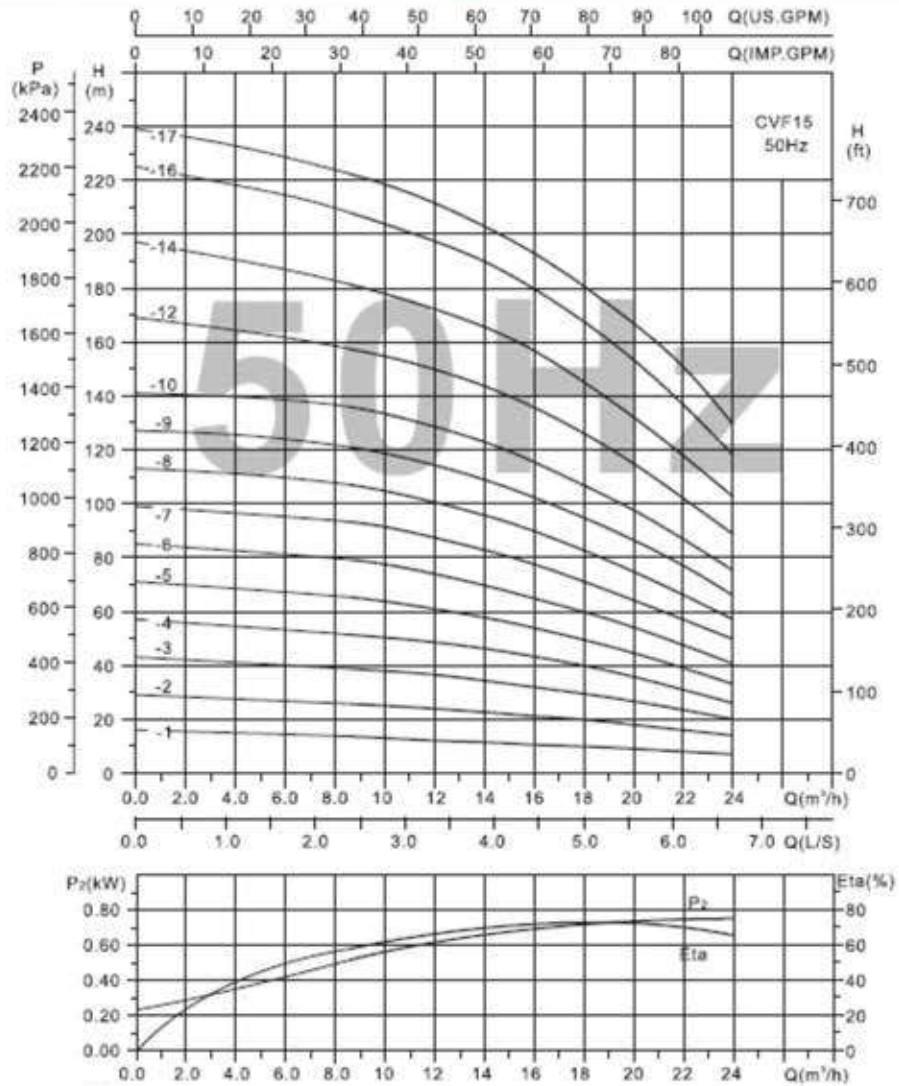

Type	P2		Flow Rate (Q)										
			m³/hr	8	10	12	14	15	16	18	20	22	24
	(HP)	(KW)	Head (H)										
CVF15-1	2	1.1	m	14	13	12	11.5	11	10.5	10	9	8	7
CVF15-2	3	2.2		26	25	24	23	22	21	20	18	16	14
CVF15-3	4	3		39	38	37	34	33	31	29	27	24	20
CVF15-4	5.5	4		52	50	48	46	44	43	40	36	31	26
CVF15-5	5.5	4		66	64	61	58	56	54	50	45	39	33
CVF15-6	7.5	5.5		80	78	75	70	67	65	60	54	47	41
CVF15-7	7.5	5.5		94	92	88	83	80	78	71	64	56	50
CVF15-8	10	7.5		108	105	101	96	93	90	83	75	66	57
CVF15-9	10	7.5		122	119	115	109	106	103	95	87	77	66
CVF15-10	15	11		136	133	128	123	120	116	107	98	86	76
CVF15-12	15	11		158	155	150	144	140	135	126	116	102	89
CVF15-14	15	11		183	178	172	165	162	156	145	133	118	103
CVF15-16	20	15.0		210	204	197	190	185	179	168	153	137	118
CVF15-17	20	15		224	218	212	203	198	193	181	166	151	129



CVF15

DIMENSIONS

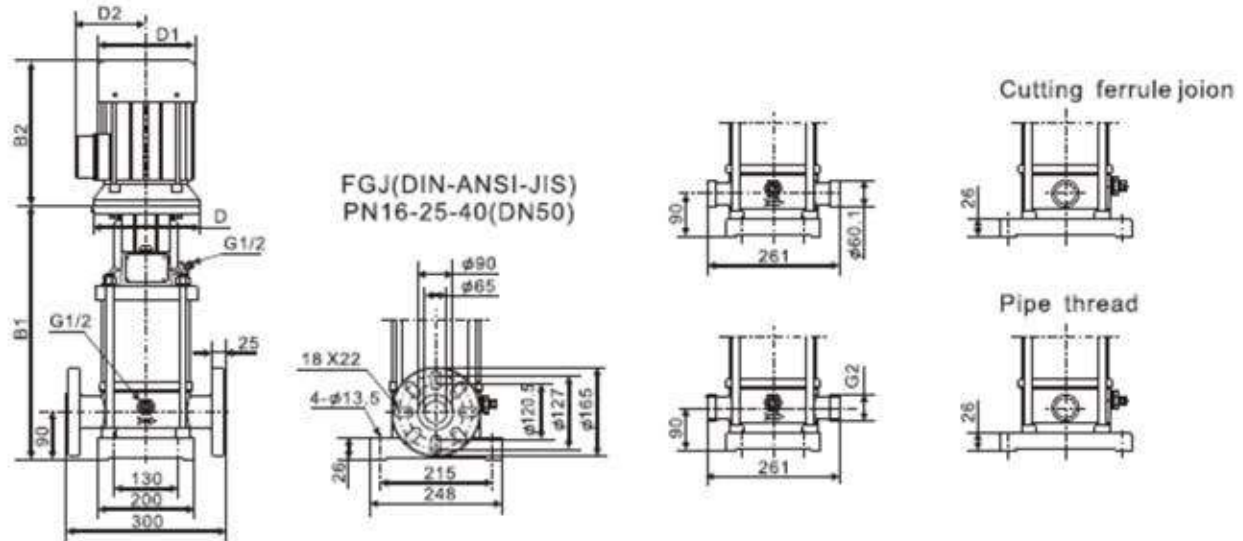

Model	Dimensions (mm)					
	B1	B2	B1+B2	D	D1	D2
CVF15-1	350	241	591	—	154	111
CVF15-2	403	275/293	678/696	—	177	116
CVF15-3	448	293	723	—	177	116
CVF15-4	513	305	768	—	197	148
CVF15-5	558	305	863	—	197	148
CVF15-6	624	390	1014	300	275	210
CVF15-7	669	390	1059	300	275	210
CVF15-8	714	390	1104	300	275	210
CVF15-9	759	390	1149	300	275	210
CVF15-10	824	505	1325	350	330	255
CVF15-12	914	505	1415	350	330	255
CVF15-14	1004	505	1505	350	330	255
CVF15-16	1094	505	1595	350	330	255
CVF15-17	1139	505	1640	350	330	255



Swimming Pools



SWIMMING POOL

Pumps

SCP →

SBP →

48 SUB →

LP →

WTP →

WP →

JA →

VAMA is a recognized global manufacturer that meets and surpasses the expectations of customers with the best-in-class products, with quality at the heart of every thing we do.

We offer specialized products of swimming pools, spa, waterparks, public aquariums, water features and sand filters

MADE IN ITALY

SCP

DESCRIPTION & APPLICATIONS:

SCP pool pump series is typical swimming pool pump applied for sauna and Spa equipment. The pump body, diffuser and impeller applied efficient structure design with max flow, max head and low noise. Liquids part is made of high reinforce engineering techno-polymer that can afford impact caused by stream. Inlet and outlet is with female or male thread for easy connection. The high reinforce engineering plastic base is vibration-resistance and corrosive-resistance. SCP series is suitable for sauna, spa pool and sand filter of swimming pool.



MAIN FEATURES:

Flow rate up to 33 m³/hr
Head up to 22 m
Max water temperature 50 °c
Ambient temperature up to 40 °c

COMPONENT CONSTRUCTION

Pump body	Reinforced techno-polymer
Pump bracket	Aluminum
Diffuser	Reinforced techno-polymer
Impeller	Reinforced techno-polymer
Pump shaft	Stainless steel AISI 316
Mechanical seal	Graphite / Silicon

MOTOR

Two-pole induction motor
External cooling
Insulation class F
Protection degree IP55
Single phase 220V/50Hz
Thermal protection
Continuous service S1



SCP

SPECIFICATIONS

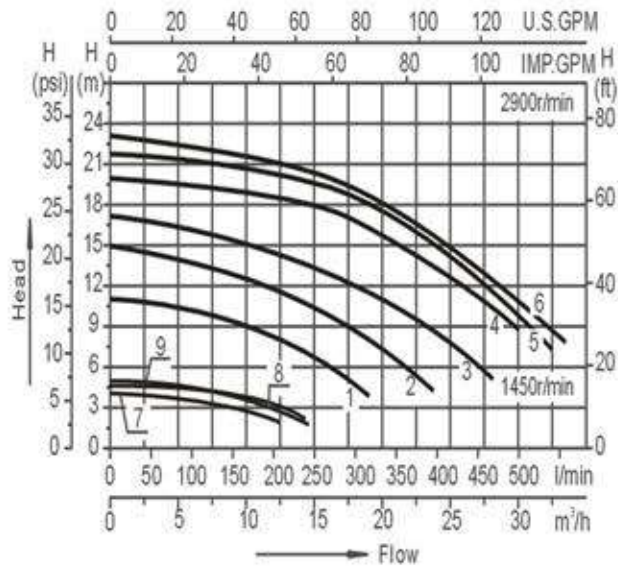

Type	P2		Curve	Ampere 1~ 230V- 50Hz	Flow Rate (Q)																															
	(HP)	(KW)			l/min		0		40		85		125		165		210		250		290		335		375		415		455		500		540		580	
					m³/hr		0		2.5		5		7.5		10		12.5		15		17.5		20		22.5		25		27.5		30		32.5		35	
SCP100	1.0	0.75	1	3.8	m		11	10.8	10	9	8	7.5	6	4.5	-	-	-	-	-	-	-	-	-	-	-	-	-	-	-	-	-	-	-			
SCP150	1.5	1.1	2	5.6	m		16	15.5	15	14	13.5	12.1	11	9.8	9	7	5	-	-	-	-	-	-	-	-	-	-	-	-	-	-	-	-			
SCP200	2.0	1.5	3	7	m		17	16.5	16	15.5	15	14	13.5	12	11	9.5	8	6	-	-	-	-	-	-	-	-	-	-	-	-	-	-				
SCP300	3.0	2.2	5	10	m		22	21.7	21.5	21	20.9	20	19.5	19	17.5	16	14	12	10	7.5	-	-	-	-	-	-	-	-	-	-	-	-				

DIMENSIONS

Model	L(mm)
scp100	635
scp150	635
scp200	635
scp300	660

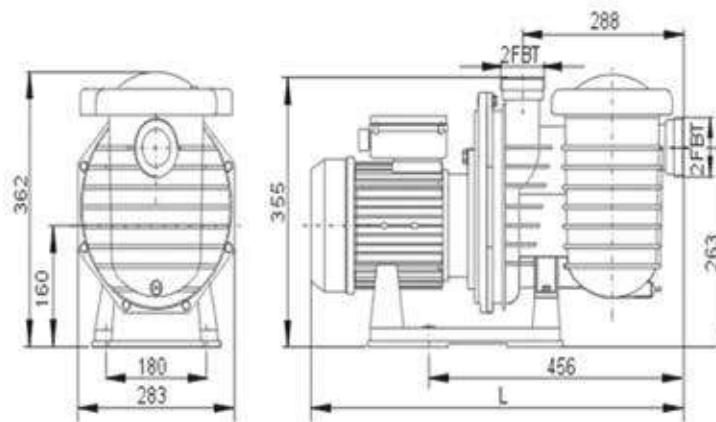

SBP

DESCRIPTION & APPLICATIONS:

SBP pool pump series, high efficient structure design for diffuser and impeller to get high performance.

Inlet and outlet is with female or male thread for easy connection.

Liquids part is made of high reinforce engineering techno-polymer with compact structure.

The high reinforce engineering plastic base is vibration-resistance and corrosive-resistance.

SBP series is preferred product for sand filter of swimming pool.



MAIN FEATURES:

Flow rate up to 22 m³/hr

Head up to 17.5 m

Max water temperature 50 °c

Ambient temperature up to 40 °c

COMPONENT CONSTRUCTION

Pump body	Reinforced techno-polymer
Pump bracket	Aluminum
Diffuser	Reinforced techno-polymer
Impeller	Reinforced techno-polymer
Pump shaft	Stainless steel AISI 316
Mechanical seal	Graphite / Silicon

MOTOR

Two-pole induction)
External cooling
Insulation class F
Protection degree IP55
Single phase 220V/50Hz
Thermal protection
Continuous service S1



SBP

SPECIFICATIONS

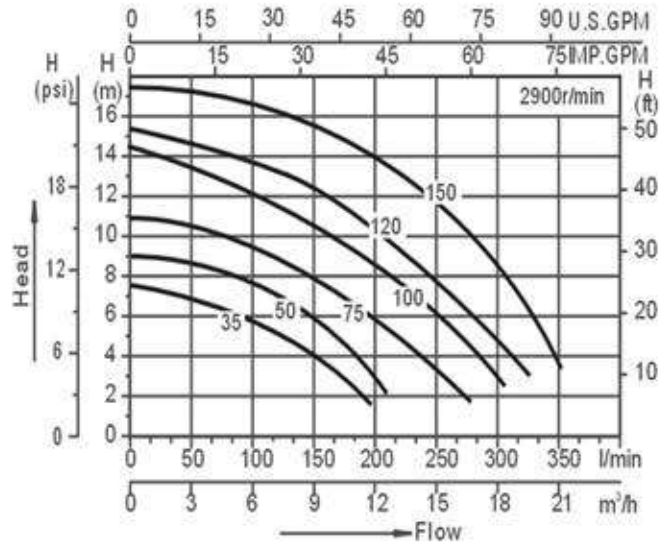

Type	P2		Ampere 1~ 230V- 50Hz	Flow Rate (Q)								
				l/min	0	50	100	150	200	250	300	350
	(HP)	(KW)	m³/hr	0	3	6	9	12	15	18	21	
SBP150	1.5	1.1	5.8	Head (H)								
				m	17.5	17	16.3	15	13.5	11.5	8	4

DIMENSIONS

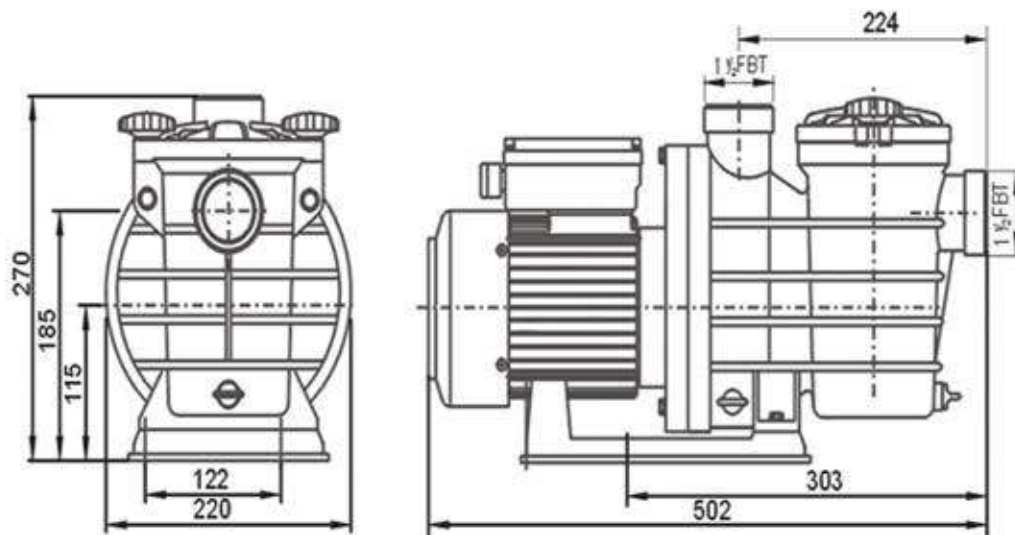

48 SUP

DESCRIPTION & APPLICATIONS:

SUP series is single stage, centrifugal pumps with built in filter designed to operate with water pool cleaning and water circulation.

The pump body, pump cover and impeller are made of reinforced engineering techno-polymer.

The high reinforce engineering plastic base is vibration-resistance and corrosive-resistance.

SUP series is preferred product for sand filter of swimming pool



MAIN FEATURES:

Flow rate up to 25 m³/hr

Head up to 17 m

Max water temperature 50 °c

Ambient temperature up to 40 °c

COMPONENT CONSTRUCTION

Pump body	Reinforced techno-polymer
Pump bracket	Aluminum
Diffuser	Reinforced techno-polymer
Impeller	Reinforced techno-polymer
Pump shaft	Stainless steel AISI 316
Mechanical seal	Graphite / Silicon

MOTOR

Two-pole induction motor
Internal cooling
Insulation class F
Protection degree IP55
Single phase 220V/50Hz
Thermal protection
Continuous service S1



48 SUP

SPECIFICATIONS

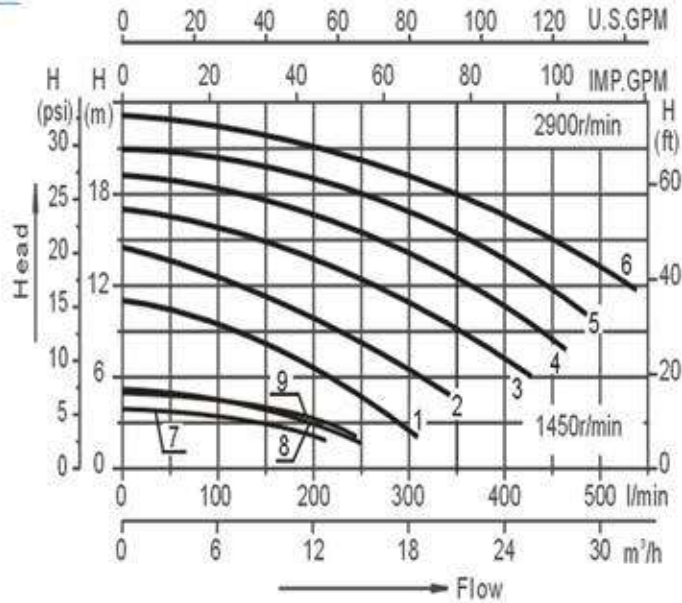

Type	P2		Ampere	Flow Rate (Q)							
				1~ 230V-50Hz	l/min	0	100	200	300	400	500
					m³/hr	0	6	12	18	24	30
48sup	(HP)	(KW)	5.2	Head (H)							
	1.5	1.1		m	17	16	14	11	7		

DIMENSIONS

Model	L(mm)
48SUP	628

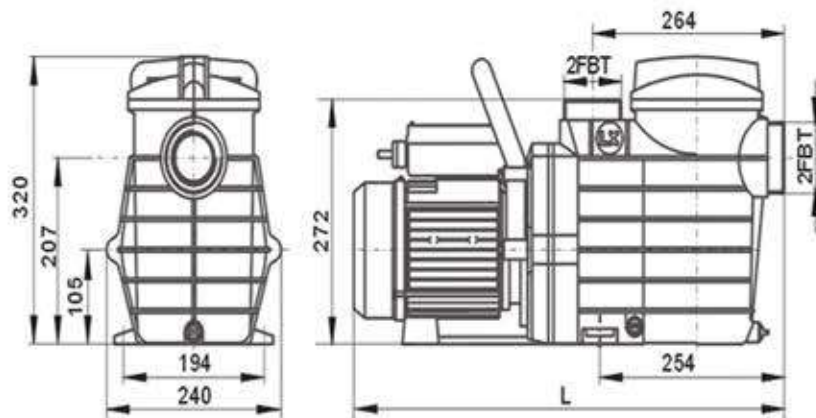

LP

DESCRIPTION & APPLICATIONS:

LP Series preferred product for SPA pool. pump casing is volute design with high-performance and large flow and low-noise. 2" inlet and Outlet, Pump housing could be 90°flexible installations for easy pipe work.

Liquids part is made of high reinforce engineering techno-polymer.

LP Series suitable for hydro massage tube or boosting of spa system and cycle or filter of swimming pool system.



MAIN FEATURES:

- Flow rate up to 38 m3/hr
- Head up to 17 m
- Max water temperature 50 °c

COMPONENT CONSTRUCTION

- | | |
|-------------------|---------------------------|
| - Pump body | Reinforced techno-polymer |
| - Pump bracket | Aluminum |
| - Impeller | Reinforced techno-polymer |
| - Pump shaft | Stainless steel AISI 316 |
| - Mechanical seal | Graphite / Silicon |

MOTOR

- Two-pole induction motor
- External cooling
- Insulation class F
- Protection degree IP55
- Single phase 220V/50Hz
- Thermal protection
- Continuous service S1



LP

SPECIFICATIONS

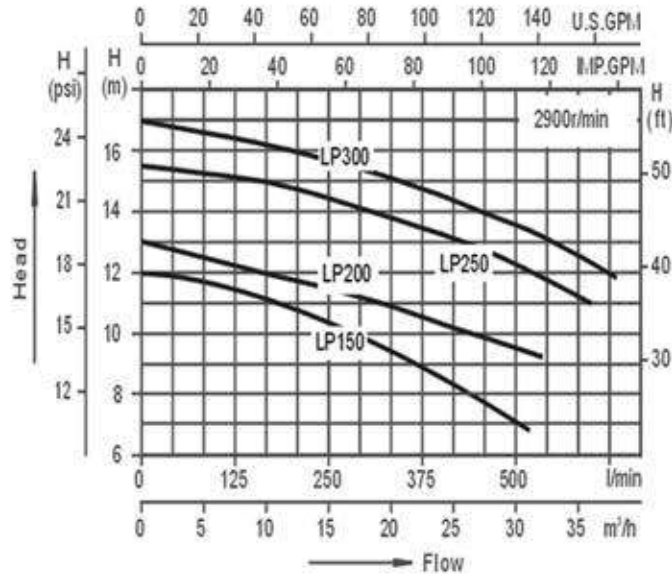

Type	P2		Ampere 1~ 230V- 50Hz	Flow Rate (Q)									
				l/min m³/hr	0	85	165	250	335	415	500	585	675
	(HP)	(KW)	Head (H)										
LP150	1.5	1.1	5.8	m	12	11.8	11	10.4	9.5	8.3	4	-	-
LP200	2.0	1.5	7.0		13	12.5	12	11.5	10.9	10.2	9.5	-	-
LP250	2.5	1.85	8.0		15.5	15.2	15	14.5	13.8	13	12.2	11.1	-
LP300	3.0	2.2	10		17	16.6	16.2	15.7	15	14.4	13.5	12.5	-

DIMENSIONS

Model	L(mm)
LP150	382
LP200	382
LP250	382
LP300	397

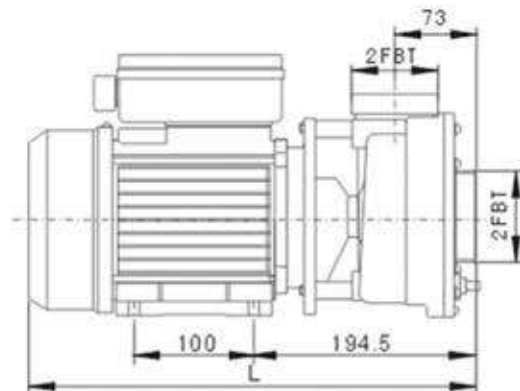
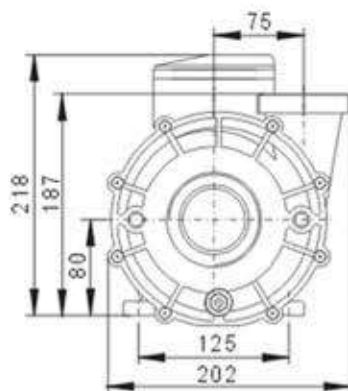

WTB

DESCRIPTION & APPLICATIONS:

WTB series spa pool pump for filter and cycle system. pump casing is volute design with high-performance and large flow and low-noise. Pump housing could be 90°flexible installations for easy pipe work. Liquids part is made of high reinforce engineering techno-polymer. WTB Series suitable for hydro massage tube or boosting of spa system and cycle or filter of swimming pool system.



MAIN FEATURES:

- Flow rate up to 90 m3/hr
- Head up to 18 m
- Max water temperature 50 °c
- Ambient temperature up to 40 °c

COMPONENT CONSTRUCTION

- Pump body Reinforced techno-polymer
- Pump bracket Aluminum
- Impeller Reinforced techno-polymer
- Pump shaft Stainless steel AISI 316
- Mechanical seal Graphite / Silicon

MOTOR

- Two-pole induction motor
- External cooling
- Insulation class F
- Protection degree IP55
- Single phase 220V/50Hz
- Three phase 380V/50Hz
- Thermal protection (for single phase)
- Continuous service S1



WTB

SPECIFICATIONS

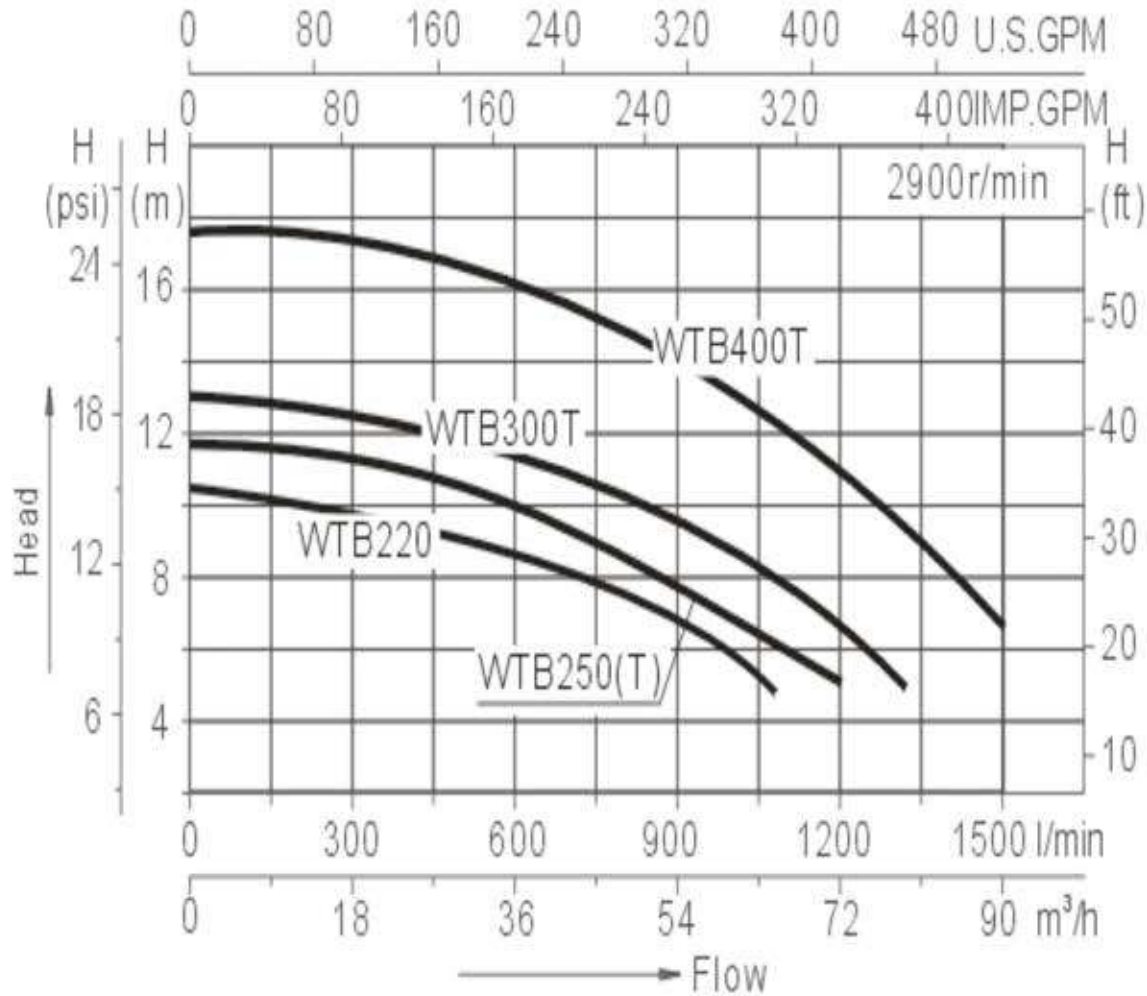

Type	P2		Ampere		Flow Rate (Q)											
			1~ 230V-50Hz	1~ 380V-50Hz	l/min m³/hr	0	150	300	450	600	750	900	1045	1200	1345	1500
	(HP)	(KW)	Head (H)													
WTB220	3.0	2.2	10	-	m	11	10	9.8	9.5	8.5	8	7	5	-	-	-
WTB250	3.5	2.5	13.7	-		11.5	11	10.7	10	9.5	9	8	6.4	5	-	-
WTB300	4.0	3.0	-	5.2		13	12.7	12.5	12	11.5	10.5	9.8	8	7	-	-
WTB400	5.5	4.0	-	7.0		18	18	17.5	17	16	15	14	12.5	11	9	7



WTB

DIMENSIONS

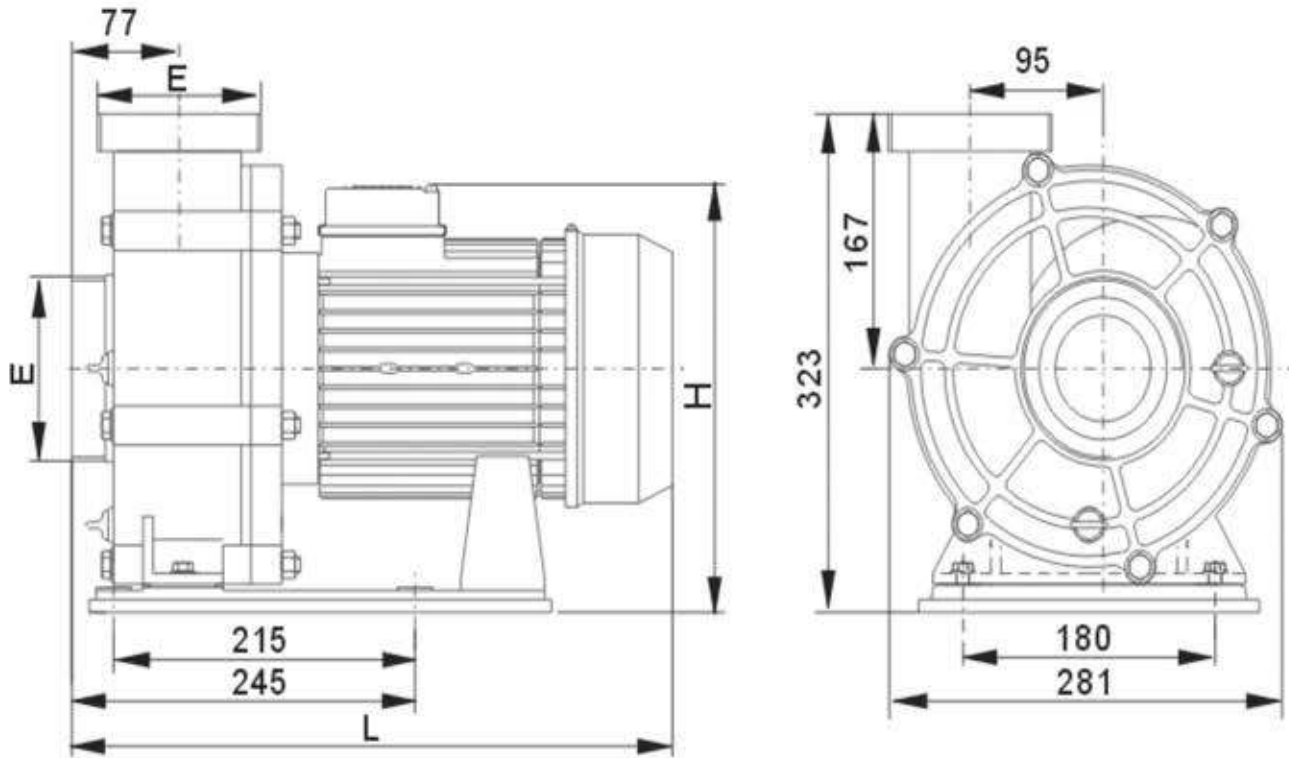

Model	Dimensions (mm)		E
	L	H	
WTB220	412	301	G2¾ or G4
WTB250	412	301	
WTB300	412	274	
WTB400	429	274	



WP

DESCRIPTION & APPLICATIONS:

WP series spa pool pump is 2 speed pumps for SPA pool that achieve to high-speed for massage and low speed for filter and cycle functions. pump casing is volute design with high-performance and large flow and low-noise. Pump housing could be 90°flexible installations for easy pipe work.

Liquids part is made of high reinforce engineering techno-polymer.

WP Series suitable for hydro massage tube or boosting of spa system and cycle or filter of swimming pool system.

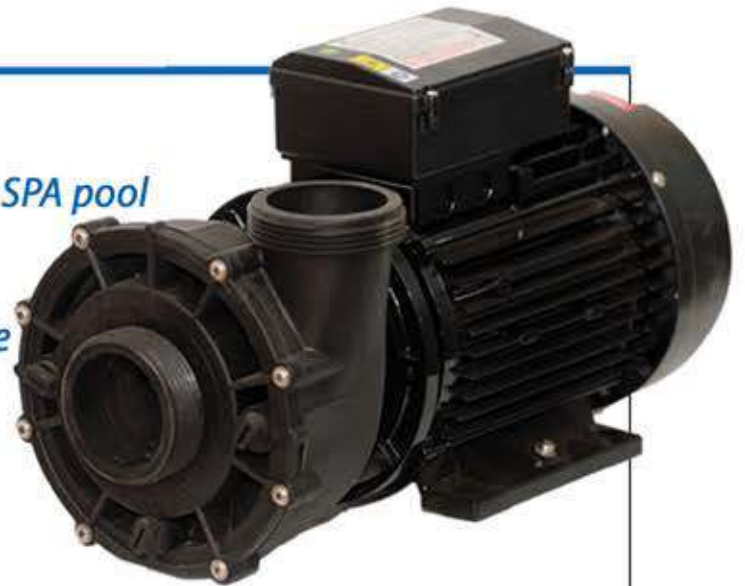

MAIN FEATURES:

- Flow rate up to 67 m³/hr
- Head up to 18 m
- Max water temperature 50 °c
- Ambient temperature up to 40 °c

MOTOR

- Two-pole induction motor
- External cooling
- Insulation class F
- Protection degree IP55
- Single phase 220V/50Hz
- Thermal protection (for single phase)
- Continuous service S1

COMPONENT CONSTRUCTION

- | | |
|-------------------|---------------------------|
| - Pump body | Reinforced techno-polymer |
| - Pump bracket | Aluminum |
| - Impeller | Reinforced techno-polymer |
| - Pump shaft | Stainless steel AISI 316 |
| - Mechanical seal | Graphite / Silicon |



WP

SPECIFICATIONS

WP500-11

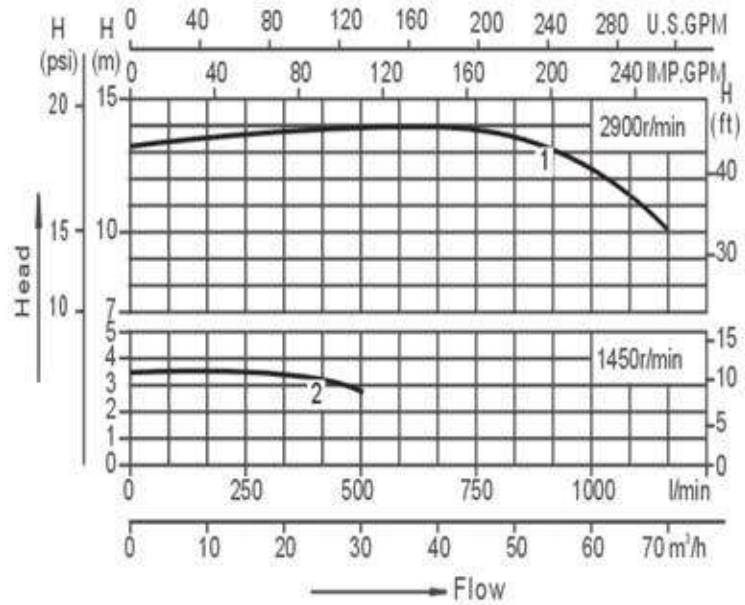
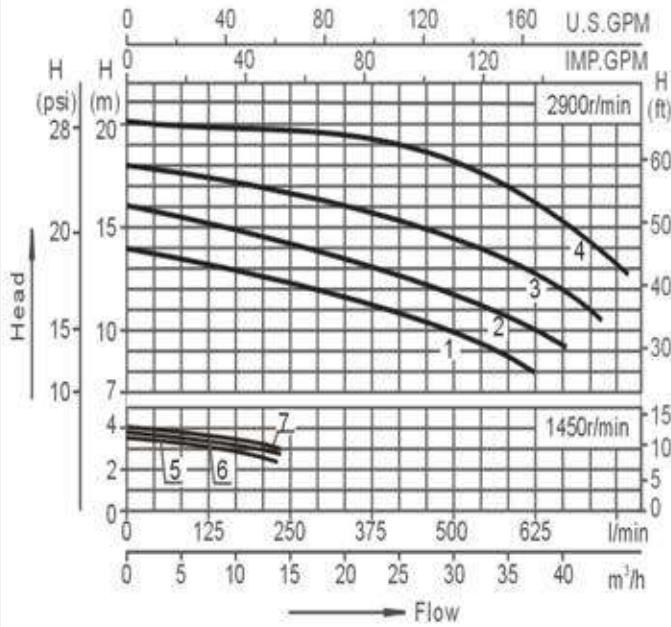

Type	P2 (HP) (KW)		Ampere 1~ 230V-50Hz	Flow Rate (Q)																															
				l/min		0		85		165		250		335		415		500		585		665		750		830		915		1000		1080		1166	
				m³/hr		0		5		10		15		20		25		30		35		40		45		50		55		60		65		70	
				Head (H)																															
				m																															
WP 200-II	2.0	1.5	2.0	14	13.5	13	12.3	11.5	11	10	8.7	-	-	-	-	-	-	-	-	-	-	-	-	-	-	-	-	-	-	-	-				
WP 250-II	2.5	1.85	2.5	16	15.5	15	14.1	13.5	12.7	11.5	10.5	9.2	-	-	-	-	-	-	-	-	-	-	-	-	-	-	-	-	-	-	-				
WP 300-II	3.0	2.2	3.0	18	17.5	17	16.6	16	15.3	14.5	13.5	12	-	-	-	-	-	-	-	-	-	-	-	-	-	-	-	-	-	-	-				
WP 500-II	5.0	3.7	4.5	13.2	13.4	13.5	13.6	13.8	13.9	14	14	14	14	13.9	13.5	13	12.5	11.5	10	-	-	-	-	-	-	-	-	-	-	-	-				



WP

DIMENSIONS

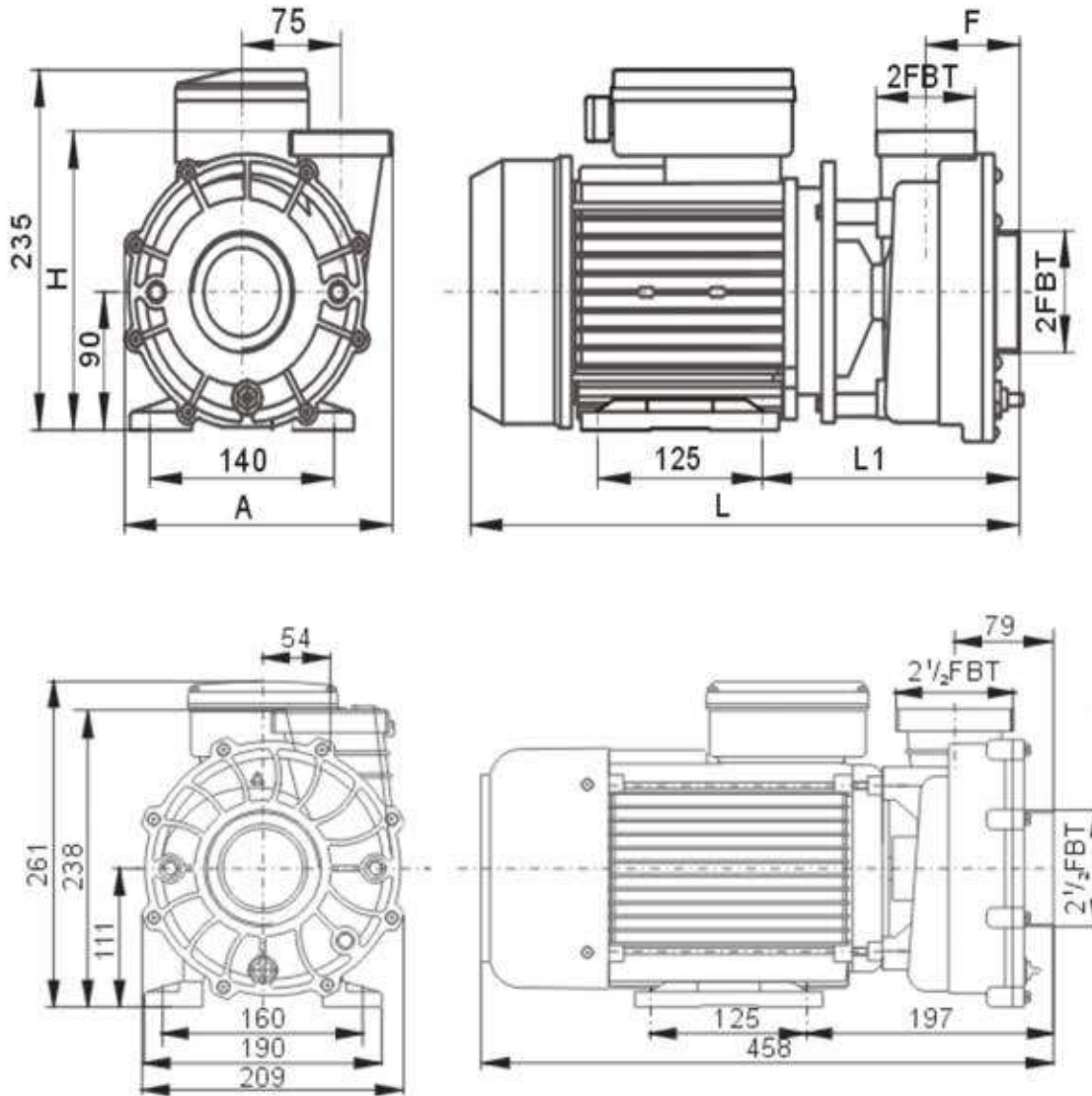

Model	Dimensions (mm)				
	A	H	L	L1	F
WP200-II	202	197	434	197	73
WP250-II	202	197	434	197	73
WP300-II	202	197	434	197	73
WP500-II	ON GRAPH				



JA

DESCRIPTION & APPLICATIONS:

JA series is suitable for hydro massage. Liquids part is made of high reinforce engineering techno-polymer. pump casing design with high-performance and low-noise

JA Series suitable for hydro massage tube or boosting of spa system and cycle or filter of swimming pool system.



MAIN FEATURES:

- Flow rate up to 90 m3/hr
- Head up to 18 m
- Max water temperature 50 °c
- Ambient temperature up to 40 °c

COMPONENT CONSTRUCTION

- Pump body Reinforced techno-polymer
- Pump bracket Aluminum
- Impeller Reinforced techno-polymer
- Pump shaft Stainless steel AISI 316
- Mechanical seal Graphite / Silicon

MOTOR

- Two-pole induction motor
- External cooling
- Insulation class F
- Protection degree IP55
- Single phase 220V/50Hz
- Thermal protection
- Continuous service S1



JA

SPECIFICATIONS

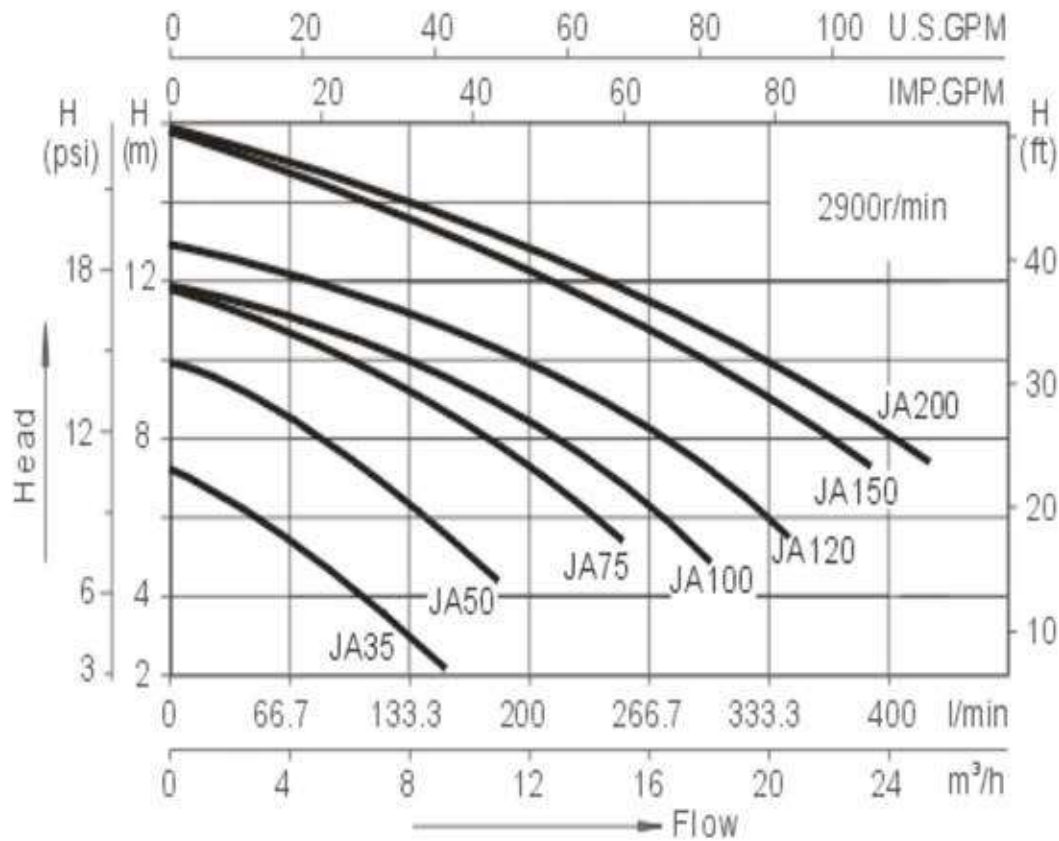

Type	P2		Ampere 1~ 230V-50Hz	Flow Rate (Q)									
				l/min m³/hr	0	65	135	200	265	335	400	465	
	(HP)	(KW)	Head (H)										
JA 35	0.35	0.25	1.6		7.5	5	3	-	-	-	-	-	-
JA 50	0.50	0.37	2		10	8.5	6.5	4	-	-	-	-	-
JA 75	0.75	0.55	3.2		12	10.5	9	7	4.5	-	-	-	-
JA 100	1.0	0.75	3.8		12	11	10	8.5	6.5	-	-	-	-
JA 120	1.2	0.9	4.6		13	12	11.5	10	8.5	6	-	-	-
JA 150	1.5	1.1	5.8		16	14.5	13.5	12.5	11	9	-	-	-



JA

DIMENSIONS

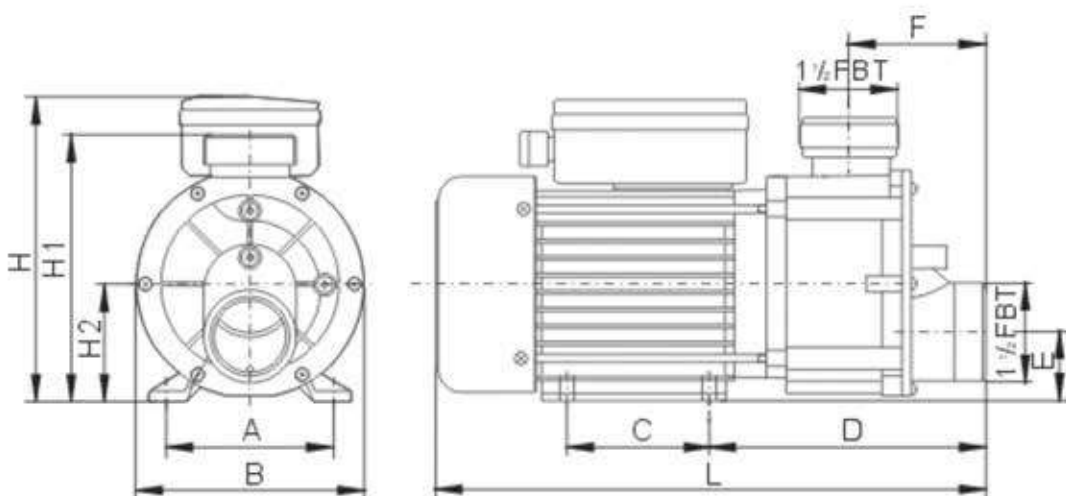

Model	Dimensions (mm)									
	A	B	C	D	E	F	L	H	H1	H2
JA35	100	153	80	164	33	89	317	191	168	63
JA50	100	153	80	164	33	89	317	191	168	63
JA75	112	156	90	172	44	86	347	205	179	74
JA100	112	156	90	172	44	86	347	205	179	74
JA120	112	156	90	172	44	86	347	205	179	74
JA150	121	187	90	218	38	120	402	210	211	90





VA-MA
swimming pool
pumps

*Always
Safe
&
Secured*



Submersible Pumps

SUBMERSIBLE Pumps

DIA.4 →

QJD →

BH →

DIA.6 →

BP →

Range of submersible pumps from 4", 5", 6", 8", 10" and 12" radial-flow and mixed-flow type, high-yield, to work perfectly on the duty point.

They are sized well, easy to disassemble and studied to ensure optimum durable use of your electropumps to work for long time granting great efficiency.

MADE IN ITALY

QJD

100 QJD-YD

100 QJD Series oil-filled type single phase submersible motor

APPLICATION AREA:

MOTOR

Single phase power: 0.37 to 2.2 Kw

Speed: 2850 rpm

Voltage: 220V /50Hz

Insulation class: B

Production grade: IP 58

Highest temperature of liquid: 35°C

Maximum content of solid substance: 40gr/m³

Motor casing: stainless AISI 304 AISI 201

With sandproof cover

Max. PH value within 6.5-8.5

Max. Voltage Fluctuation: ± 5%

Max. Frequency Fluctuation: ± 1%

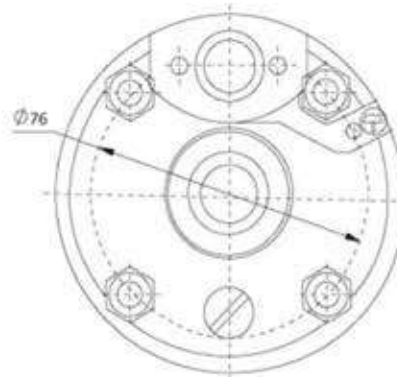
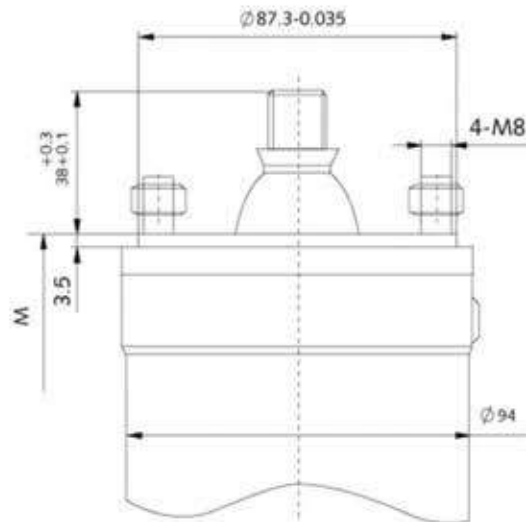

QJD YD

- 1.D means new model
- 2.Y means the motor filled with oil
- 3.The rated power by kW unit
- 7.With D is single phase, without D is three phase
- 8.Deep well pump
- 9.Diameter of pump

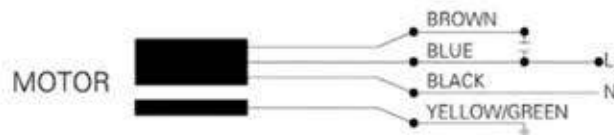

TYPE	MOTOR POWER		CAPACITOR	CURRENT MAX.	EFFICIENCY	DIMENSION	WEIGHT
Single phase 220V/50Hz	kW	HP	450V μ F	A	η %	mm	Kg
0.37YD	0.37	0.5	25	3.2	57	393	7.9
0.55YD	0.55	0.75	35	4.5	60	423	9.25
0.75YD	0.75	1	40	5.8	63	460	10.3
1.1YD	1.1	1.5	45	8.2	66	500	12.45
1.5YD	1.5	2	65	10.8	68	565	14.5
2.2YD	2.2	3	80	15.6	69	686	19.41



QJD

THE STRUCTURE, CODE AND NAME OF THE PUMP

Y(T) Pump And Motor

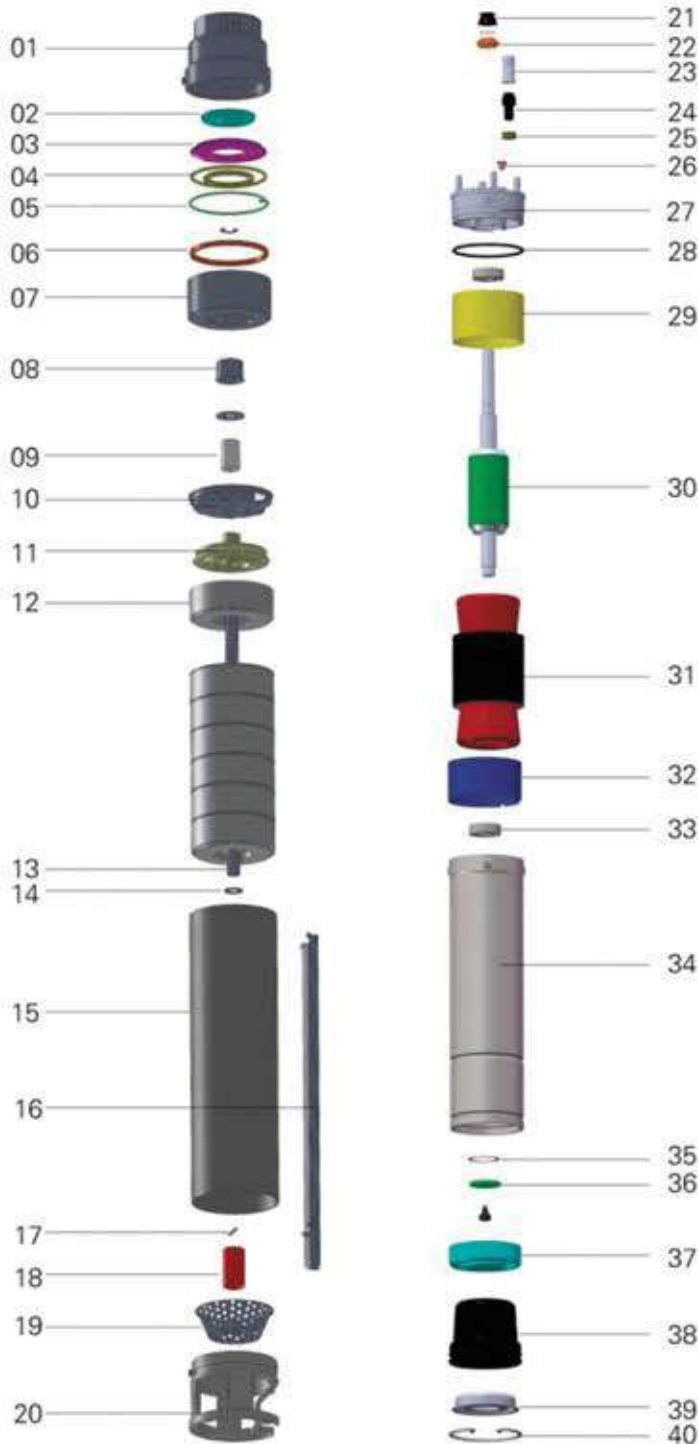

NO.	NAME
01	Outlet
02	NRV stopper
03	Non-return valve
04	"O" ring
05	Clamping spring
06	Ring
07	Upper bearing block
08	Rubber bearing
09	Upper shaft sleeve
10	Diffuser
11	Impeller
12	Diffuser cover
13	Shaft
14	Adjustable washer
15	Coupling fixed pin
16	Shell
17	Cable shield
18	Coupling fixed pin
19	Strainer
20	Inlet
21	Thrower
22	Anti-sand cover
23	cable shield
24	cable shield
25	Washer
26	Bolt
27	Oil chamber
28	"O" ring
29	Upper check ring for motor
30	Rotor
31	Stator
32	Bottom check ring for motor
33	Bearing
34	Pump casing
35	Slim
36	Round plate
37	Bottom bearing cover
38	Rubber cup
39	End cover
40	Clamping ring



QJD

CONTROL BOX



MODEL NO	POWER	RATED CURRENT	CAPACITOR	THERMAL PROTECTOR
220V/50HZ	KW	A	μF	A
QJD-0.25	0.25	2.5	12	6
QJD-0.37	0.37	3.28	15	6
QJD-0.55	0.55	4.6	20	8
QJD-0.75	0.75	6	25	10
QJD-1.1	1.1	8.4	35	12
QJD-1.5	1.5	11	45	20
QJD-2.2	2.2	15.5	55	25

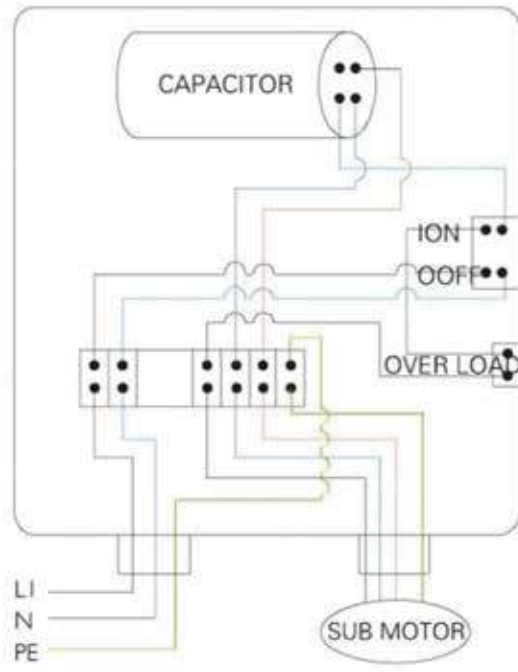
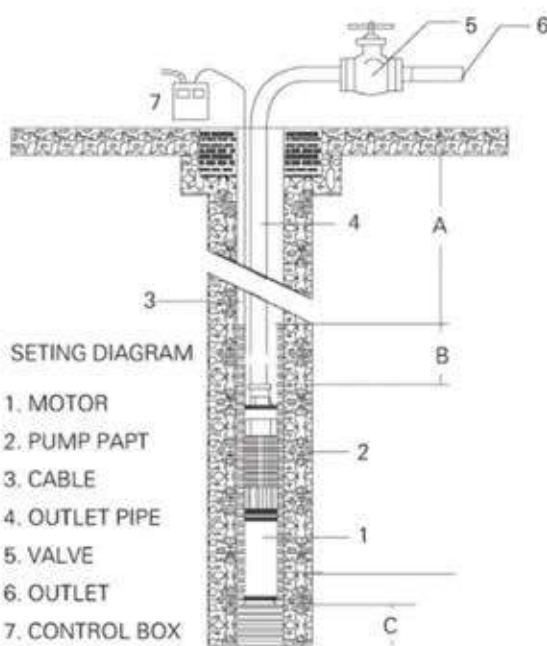
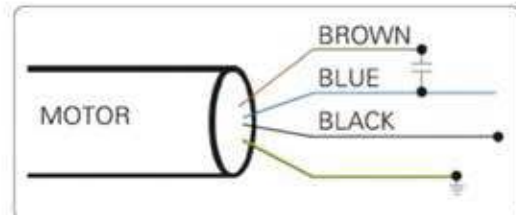

QJD2

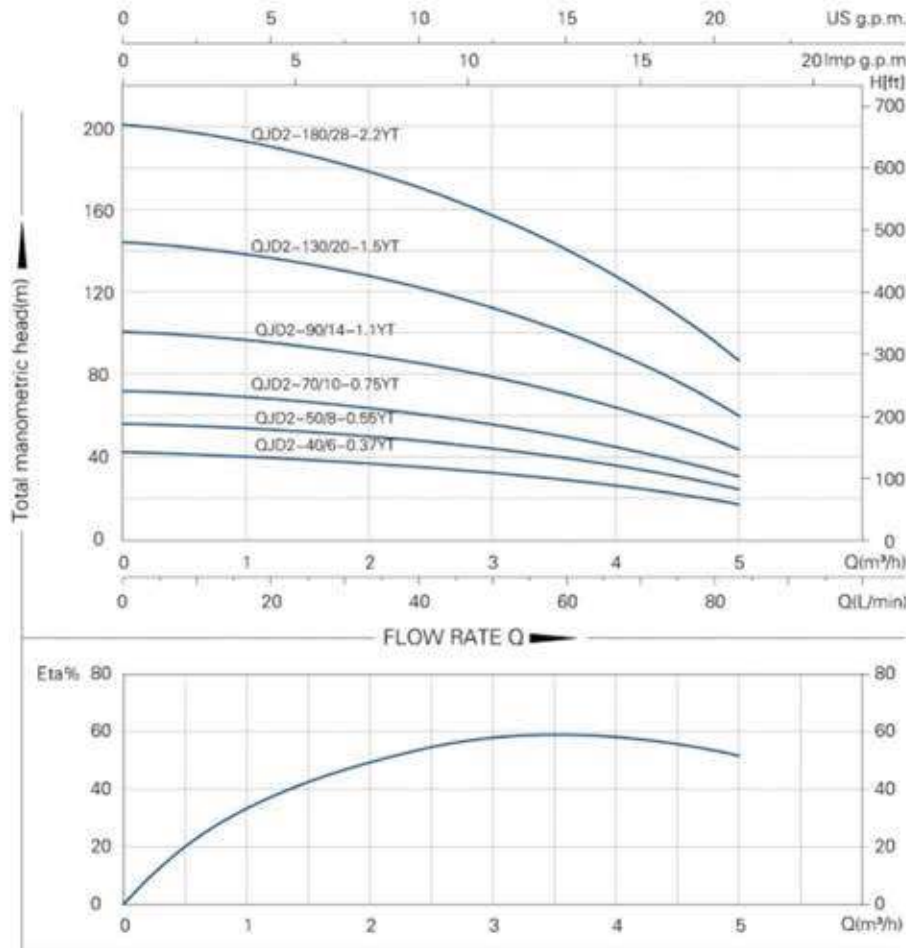

100QJD2(YT)



TYPE		MOTOR POWER		G.W.		CAPACITY						CYLINDER PACKING DIMENSION		
SINGLE PHASE 220-240V/50Hz	THREE PHASE 380-415V/50Hz	kW	HP	Single kg	Three kg	Q(m³/h)	0	1	2	3	4	5	Single Phase	Three Phase
						L/min	0	16.7	33.4	50.1	66.8	83.5	mm	
QJD2-40/6-0.37YT	QJ2-40/6-0.37YT	0.37	0.55	9.8	9.4	HEAD (M)	43	41	38	33	27	18	110X110X865	110X110X860
QJD2-50/8-0.55YT	QJ2-50/8-0.55YT	0.55	0.75	11.1	10.4		57	54	50	45	36	25	110X110X940	110X110X923
QJD2-70/10-0.75YT	QJ2-70/10-0.75YT	0.75	1.0	12.3	11.4		72	68	64	56	45	31	110X110X1018	110X110X1000
QJD2-90/14-1.1YT	QJ2-90/14-1.1YT	1.1	1.5	15	13.3		101	96	90	79	64	44	110X110X1215	110X110X1172
QJD2-130/20-1.5YT	QJ2-130/20-1.5YT	1.5	2.0	18	16.3		144	137	128	112	91	62	110X110X1425	110X110X1390
QJD2-180/28-2.2YT	QJ2-180/28-2.2YT	2.2	3.0	21.8	19.8		201	191	180	157	127	87	110X110X1800	110X110X1730
	QJ2-245/38-3YT	3.0	4.0				273	260	245	214	173	119		
	QJ2-310/50-4YT	4.0	5.5				360	342	321	282	228	157		



QJD4

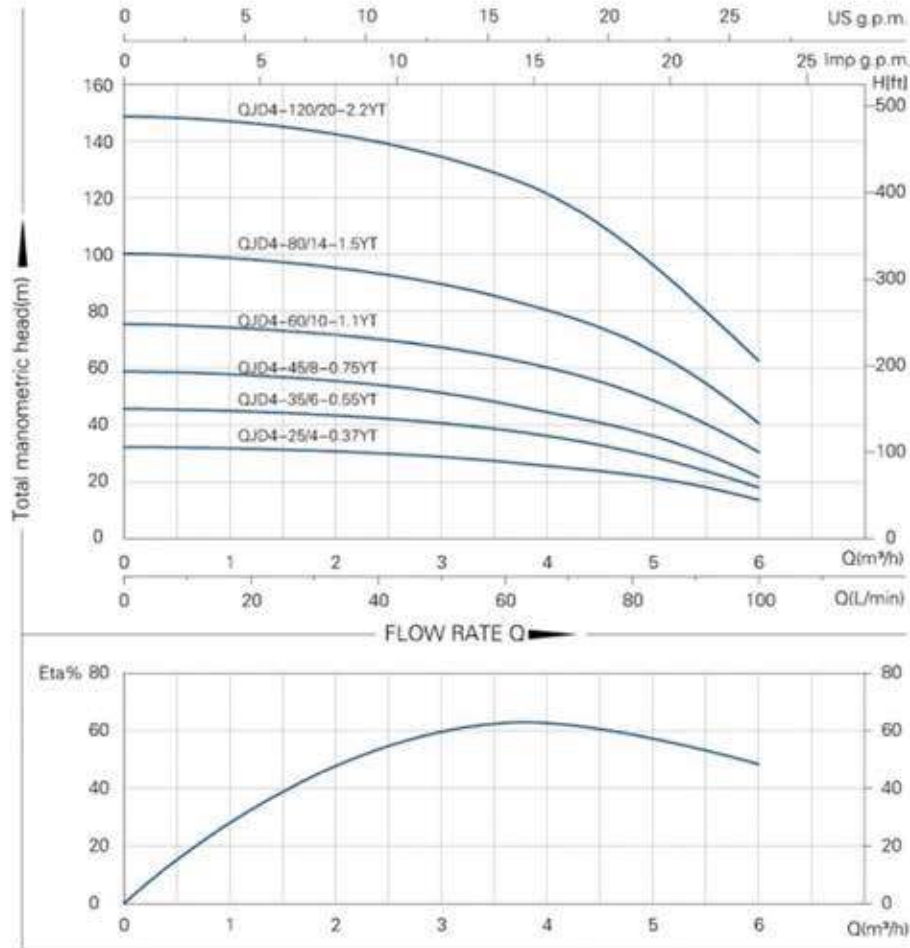

100QJD4(YT)



TYPE		MOTOR POWER		G. W.		CAPACITY							CYLINDER PACKING DIMENSION		
SINGLE PHASE 220-240V/50Hz	THREE PHASE 380-415V/50Hz	kW	HP	Single	Three	Q(m³/h) L/min	0	1	2	3	4	5	6	Single Phase	Three Phase
mm															
QJD4-25/4-0.37YT	QJ4-25/4-0.37YT	0.37	0.55	9.3	8.8	HEAD (M)	32	31	30	28	25	20	14	110X110X810	110X110X800
QJD4-35/6-0.55YT	QJ4-35/6-0.55YT	0.55	0.75	10.9	10.3		45	44	42	39	35	28	17.5	110X110X900	110X110X883
QJD4-45/8-0.75YT	QJ4-45/8-0.75YT	0.75	1.0	13.6	12.8		59.5	56	53	50	45	34.5	20	110X110X980	110X110X963
QJD4-60/10-1.1YT	QJ4-60/10-1.1YT	1.1	1.5	14.1	12.4		74.5	72.5	70	66	60	44	28	110X110X1090	110X110X1048
QJD4-80/14-1.5YT	QJ4-80/14-1.5YT	1.5	2.0	17	15.4		100	97.5	94	88	80	64	43	110X110X1290	110X110X1250
QJD4-120/20-2.2YT	QJ4-120/20-2.2YT	2.2	3.0	20.9	18.8		149	143	134.5	127	120	92	62.5	110X110X1600	110X110X1500
	QJ4-160/27-3YT	3.0	4.0				210	201	194	188	160	127	80		
	QJ4-200/35-4YT	4.0	5.5				262	251	241	227	200	150	85		



QJD6

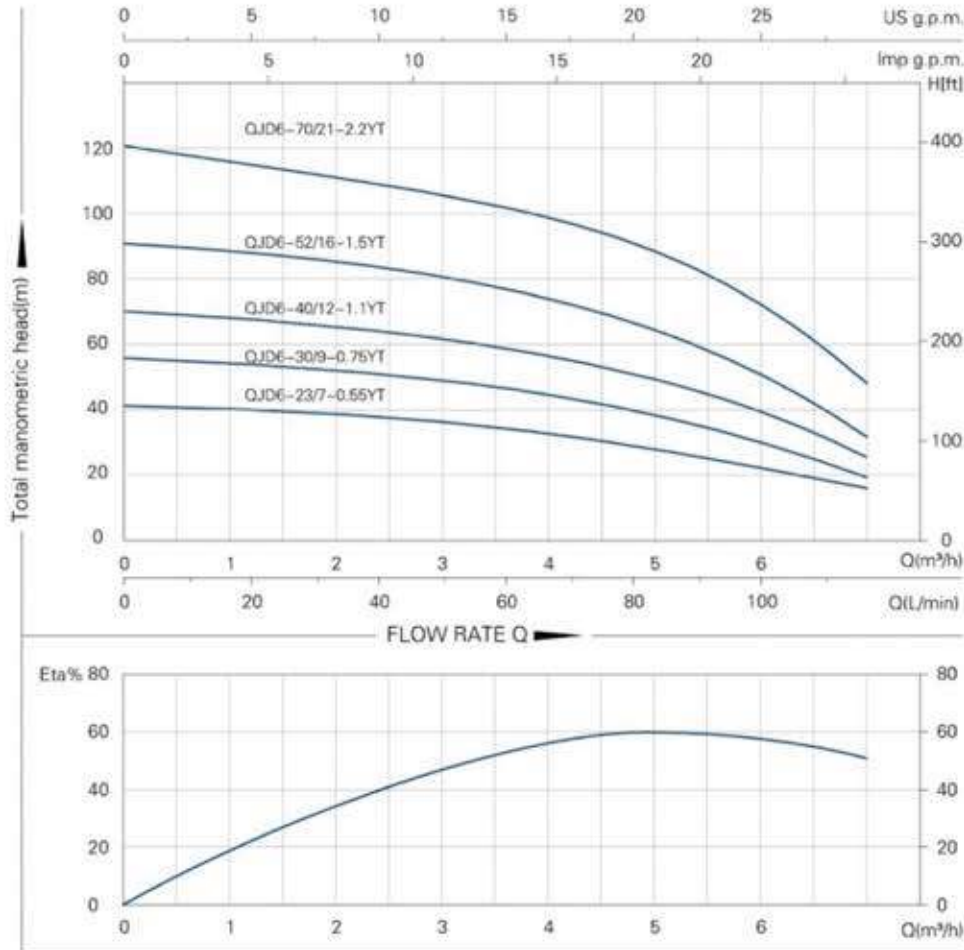

100QJD6(YT)



TYPE		MOTOR POWER		G.W.		CAPACITY						CYLINDER PACKING DIMENSION		
SINGLE PHASE 220-240V/50Hz	THREE PHASE 380-415V/50Hz	kW	HP	Single	Three	Q(m³/h)	0	3	4	5	6	7	Single Phase	Three Phase
				kg	kg								L/min	mm
QJD6-23/7-0.55YT	QJ6-23/7-0.55YT	0.55	0.75	11.1	10.5	HEAD (M)	41	35	32	29	23	16	110X110X940	110X110X992
QJD6-30/9-0.75YT	QJ6-30/9-0.75YT	0.75	1.0	12.5	11.6		55	47.5	43.5	38	30	19.5	110X110X1030	110X110X1000
QJD6-40/12-1.1YT	QJ6-40/12-1.1YT	1.1	1.5	13	12.2		71	61	56	50	40	26	110X110X1155	110X110X1120
QJD6-52/16-1.5YT	QJ6-52/16-1.5YT	1.5	2.0	17.4	14.4		91	81	74	63.5	52	33	110X110X1375	110X110X1333
QJD6-70/21-2.2YT	QJ6-70/21-2.2YT	2.2	3.0	20.9	18.8		121	105	99	90	70	48	110X110X1640	110X110X1560
	QJ6-90/26-3YT	3.0	4.0				164	138	129	117	90	66		
	QJ6-125/34-4YT	4.0	5.5				215	180	175	154	125	87		



QJD8

100QJD8(YT)

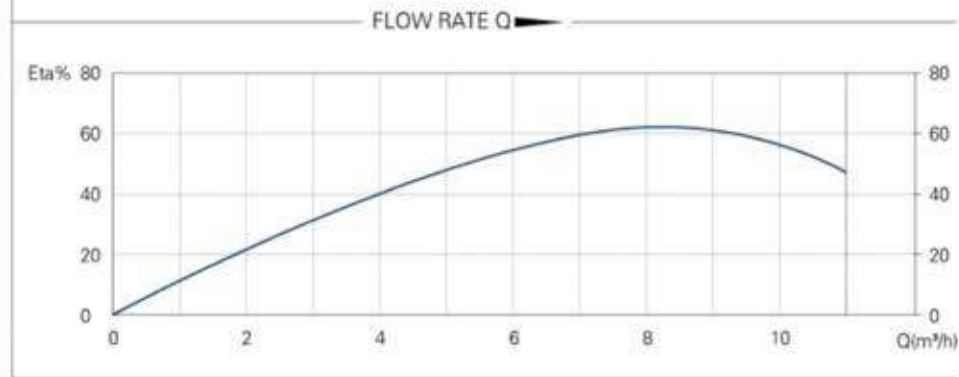
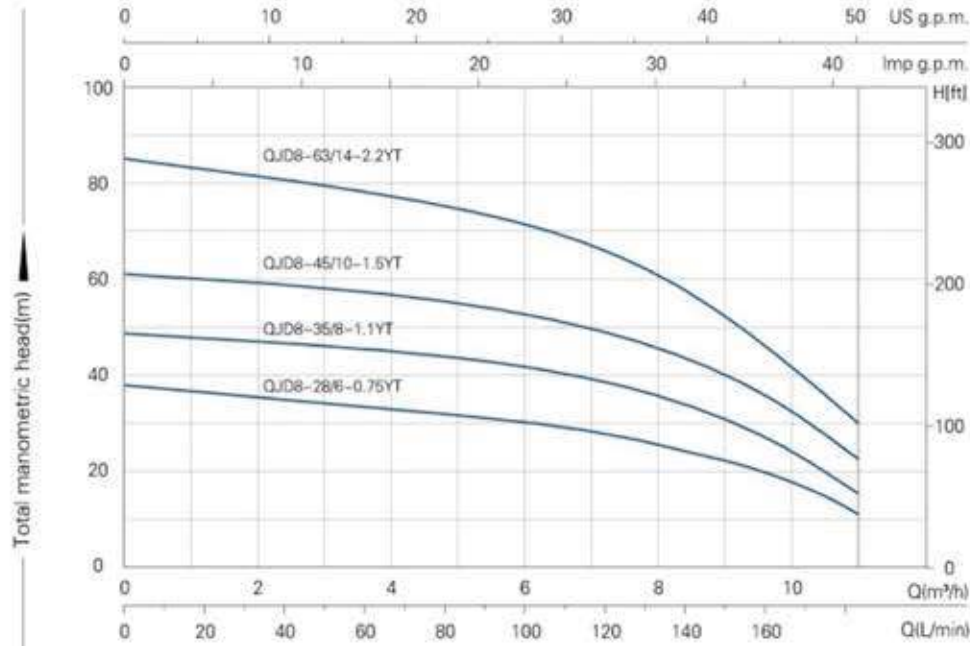

TYPE		MOTOR POWER		G.W.		CAPACITY						CYLINDER PACKING DIMENSION		
SINGLE PHASE 220-240V/50Hz	THREE PHASE 380-415V/50Hz	kW	HP	Single	Three	Q(m³/h)	0	6	7	8	9	10	Single Phase	Three Phase
mm														
QJD8-28/6-0.75YT	QJ8-28/6-0.75YT	0.75	1.0	11.6	10.8	HEAD (M)	37.5	30	29	28	21.5	16	110X110X960	110X110X940
QJD8-35/8-1.1YT	QJ8-35/8-1.1YT	1.1	1.5	12.2	11.5		49	41	39	35	31.5	25	110X110X1075	110X110X1037
QJD8-45/10-1.5YT	QJ8-45/10-1.5YT	1.5	2.0	16.3	15.5		61.5	52	49	45	40	32	110X110X1200	110X110X1155
QJD8-63/14-2.2YT	QJ8-63/14-2.2YT	2.2	3.0	19.8	17.8		85	71.5	68	63	50.5	40	110X110X1488	110X110X1400
	QJ8-85/19-3YT	3.0	4.0				110	99	90	85	68	60		
	QJ8-105/23-4YT	4.0	5.5				135	125	115	105	83	72		



QJD10

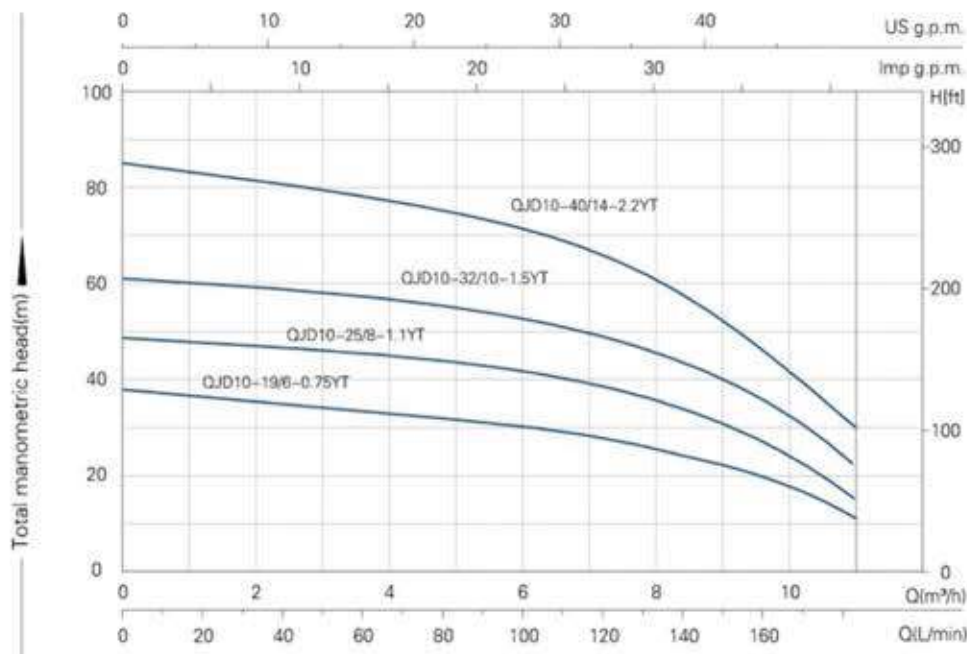

100QJD10(YT)

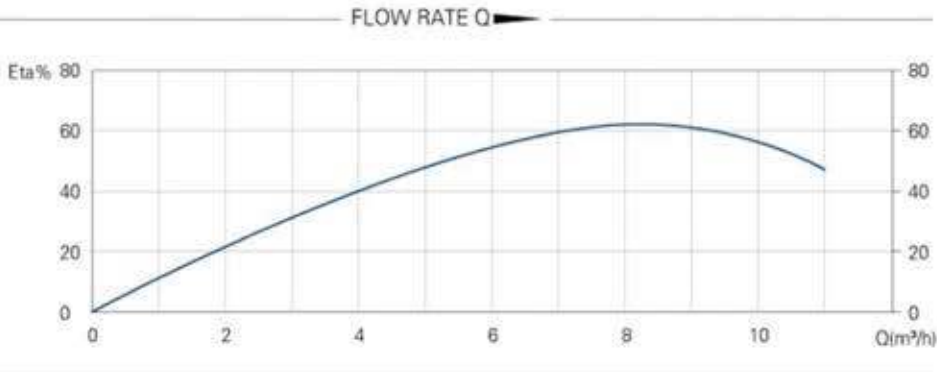

TYPE		MOTOR POWER		G. W.		CAPACITY											CYLINDER PACKING DIMENSION	
SINGLE PHASE 220-240V/50Hz	THREE PHASE 380-415V/50Hz	kW	HP	Single	Three	Q(lm³/h)	0	6	7	8	9	10	11	183	Single Phase	Three Phase		
				kg	kg												L/min	0
QJD10-19/6-0.75YT	QJ10-19/6-0.75YT	0.75	1.0	11.6	10.8	HEAD (M)	37.5	30	29	28	21.5	19	9	110X110X960	110X110X940			
QJD10-25/8-1.1YT	QJ10-25/8-1.1YT	1.1	1.5	10.8	11.5		49	41	39	36	31.5	25	16	110X110X1075	110X110X1037			
QJD10-32/10-1.5YT	QJ10-32/10-1.5YT	1.5	2.0	16.3	15.5		61.5	52	49	45	40	32	23	110X110X1200	110X110X1155			
QJD10-40/14-2.2YT	QJ10-40/14-2.2YT	2.2	3.0	19.8	17.8		85	71.5	68	63	50.5	40	30	110X110X1488	110X110X1400			
	QJ10-60/19-3YT	3.0	4.0				110	99	90	85	68	60	40					
	QJ10-72/23-4YT	4.0	5.5			135	125	115	105	83	72	65						



BH

BH SERIES 4" SUBMERSIBLE ELECTRIC PUMPS



- State-of-the-art hydraulic design and the choice of best material ensure high efficiency, best performance and reliability.

APPLICATIONS

- Water supply from deep well
- Agriculture irrigation
- Pressure boosting
- Fire-fighting
- Industrial application

SPECIFICATIONS

- Delivery: up to 22 m³/h at 2850 rpm.
- Head: up to 347 m at 2850 rpm.
- Maximum pump overall diameter (cable cover included): 99 mm.
- Maximum permissible quantity of sand: 150 g/m³.
- 2BH , 4BH , 6BH versions: delivery port Rp1"1/4.
- 8BH , 12BH , 16BH versions: delivery port Rp2".

MOTOR

- 4OS single-phase version:
from 0,25 to 2,2 kW, 220 V, 50 Hz.
- 4OS three-phase version:
from 0,37 to 2,2 kW, 220 V, 50 Hz.
from 0,37 to 7,5 kW, 380 V, 50 Hz.
- Horizontal operation: 4OS up to 2,2 kW.
- Maximum temperature of water in contact with motor: 35 °C .

CONSTRUCTION & CHARACTERISTICS

- Easy to maintain and rapid to install.
- Abrasion resistant construction, Floating impellers ensure optimum resistance to abrasion.
- The delivery port and suction support are made of precision-cast stainless steel, guarantee resistance to corrosion, durability and a sturdy coupling to the motor.
- The hexagonal pump shaft guarantees an effective impeller driving.
- A stainless steel non-return valve is fitted at the discharge to prevent back flow of water and alleviate water hammer to the pump, thus safeguarding impellers and diffusers.
- The BH series pumps can be coupled with the 4OS motors.
- Vertical and horizontal installation.
- Standard and special versions available.

OPTIONAL FEATURES

- Different voltages and frequencies.
- Different materials.



BH

BH SERIES

HYDRAULIC PERFORMANCE RANGE AT 50 Hz

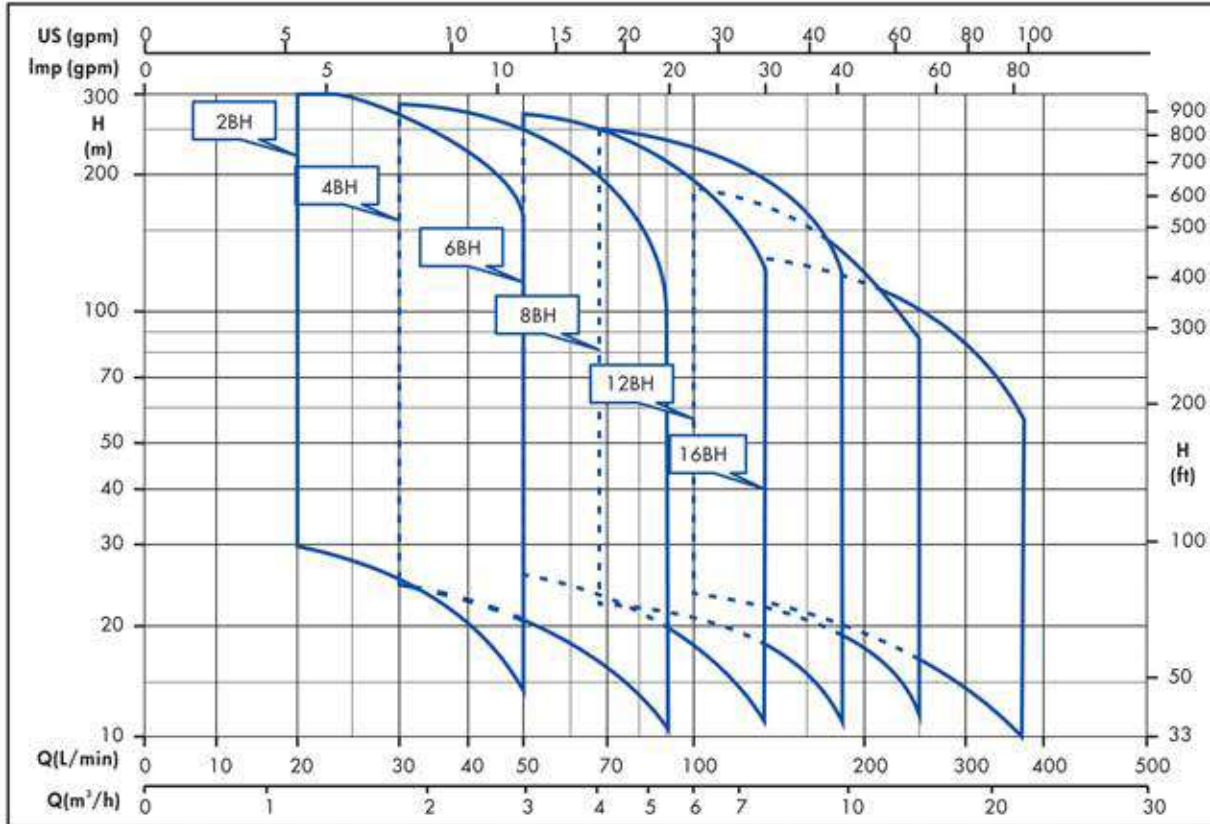

IDENTIFICATION CODE

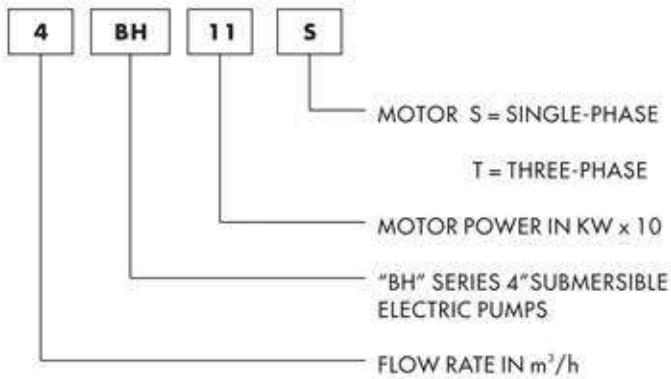

EXAMPLE OF PUMP TYPE

4BH11S

BH series 4" submersible electric pump with flow rate of $4 m^3/h$; with single-phase 1,1 kW (1,5 Hp) motor.



2BH

2BH SERIES

PUMP SECTION AND LIST OF MAIN COMPONENTS MATERIAL

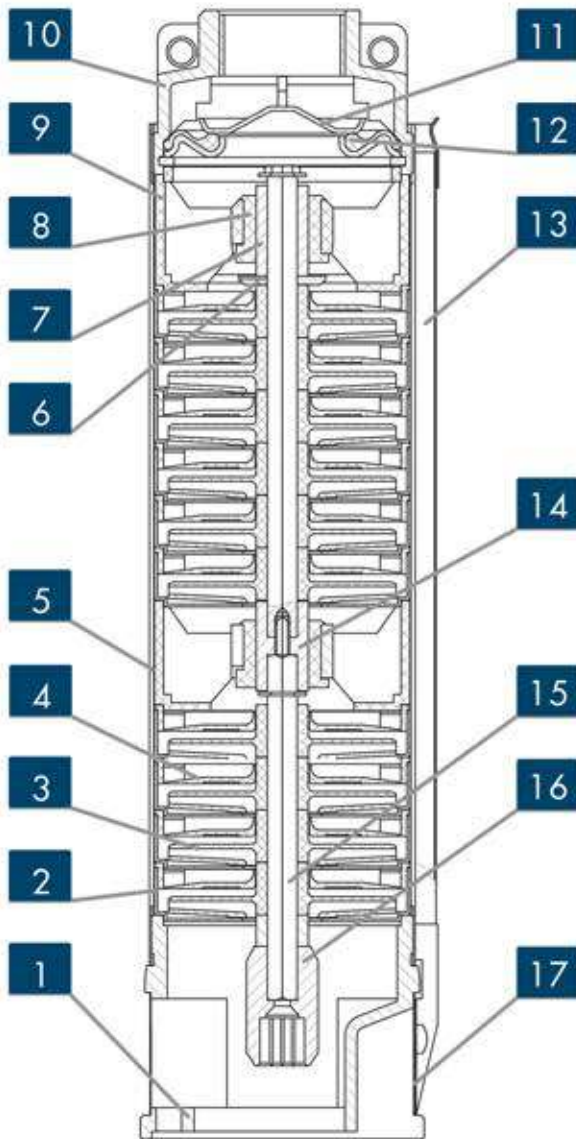

REF.N.	PART	MATERIAL	STANDARD
1	Lower support	Precision-cast stainless steel	AISI 304
2	Stage housing	Stainless steel	AISI 304
3	Impeller	Lexan® PC
4	Diffuser	Lexan® PC
5	Outer sleeve	Stainless steel	AISI 304
6	Thrust bearing	Stainless steel	AISI 304
7	Shaft sleeve	Stainless steel	AISI 304
8	Bush bearing	TPU
9	Upper support	Lexan® PC
10	Delivery port	Precision-cast stainless steel	AISI 304
11	Non-return valve	Stainless steel	AISI 304
12	Valve support with gasket	Stainless steel & NBR	AISI 304 &
13	Cable guard	Stainless steel	AISI 304
14	Intermediate Shaft sleeve	Stainless steel	AISI 304
15	Shaft	Stainless steel	AISI 420
16	Coupling	Stainless steel	AISI 304
17	Filter	Stainless steel	AISI 304



2BH

2BH SERIES

OPERATING CHARACTERISTICS AT 50 Hz

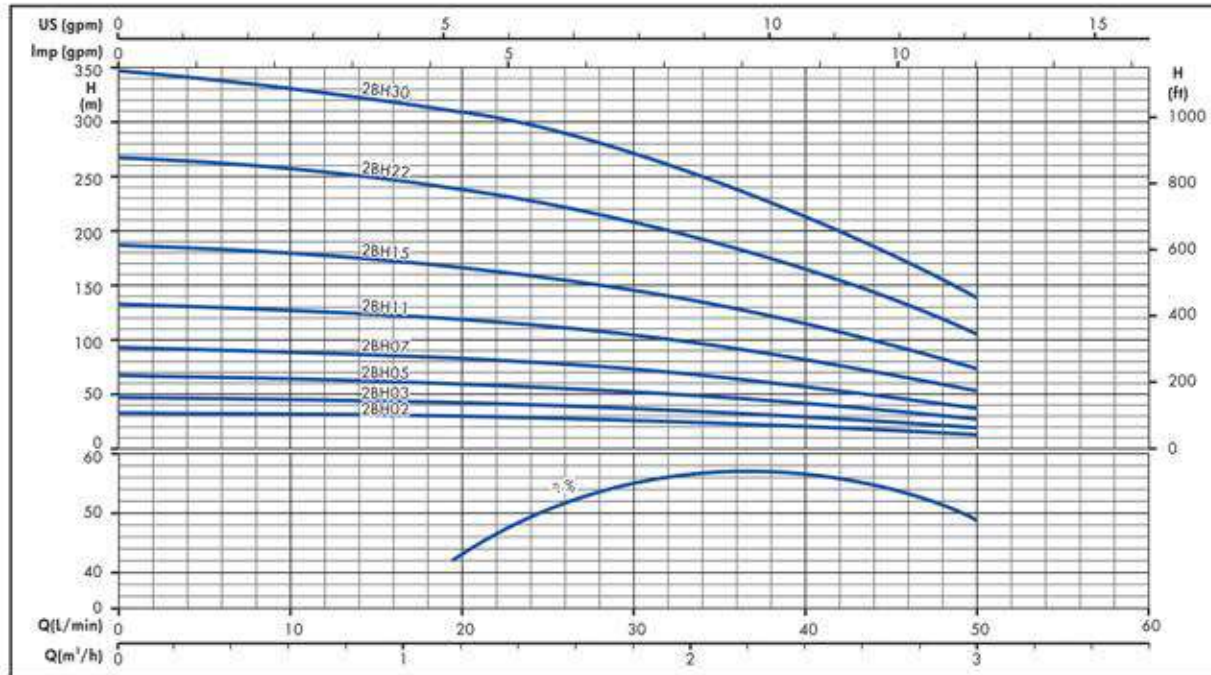

OPERATING CHARACTERISTICS AT 50 Hz

PUMP TYPE	N.OF STAGES	kW	Hp	Q = DELIVERY					
				l/min 0	20	25	30	40	50
				m³/h 0	1,2	1,5	1,8	2,4	3
				H = TOTAL HEAD METERS COLUMN OF WATER					
2BH02S	5	0,25	0,33	33	30	28	26	20	13
2BH03S	7	0,37	0,5	47	42	40	36	29	19
2BH03T									
2BH05S	10	0,55	0,7	67	60	56	52	41	27
2BH05T									
2BH07S	14	0,75	1,0	93	83	79	73	57	37
2BH07T									
2BH11S	20	1,1	1,5	133	119	113	104	82	53
2BH11T									
2BH15S	28	1,5	2,0	187	167	158	146	115	74
2BH15T									
2BH22S	40	2,2	3,0	267	238	226	208	164	106
2BH22T									
2BH30T	52	3,0	4,0	347	309	294	271	213	138

DIMENSIONS AND WEIGHTS AT 50 Hz

PUMP TYPE	N.OF STAGES	DN	L1 mm	L mm	PUMP Weight Kg	ELECTRIC PUMP Weight Kg
2BH02S	5	Rp1"1/4	252	579	2,3	10,1
2BH03S	7		287	624	2,7	10,9
2BH03T						
2BH05S	10		340	692	3,2	12,1
2BH05T						
2BH07S	14		411	783	3,9	13,7
2BH07T						
2BH11S	20		516	913	5	16,1
2BH11T						
2BH15S	28		657	1094	6,4	19,4
2BH15T						
2BH22S	40		905	1453	9,1	26,8
2BH22T						
2BH30T	52		1116	1720	11,2	31,7

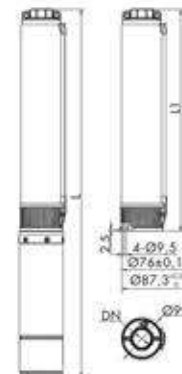

4BH

4BH SERIES

PUMP SECTION AND LIST OF MAIN COMPONENTS MATERIAL

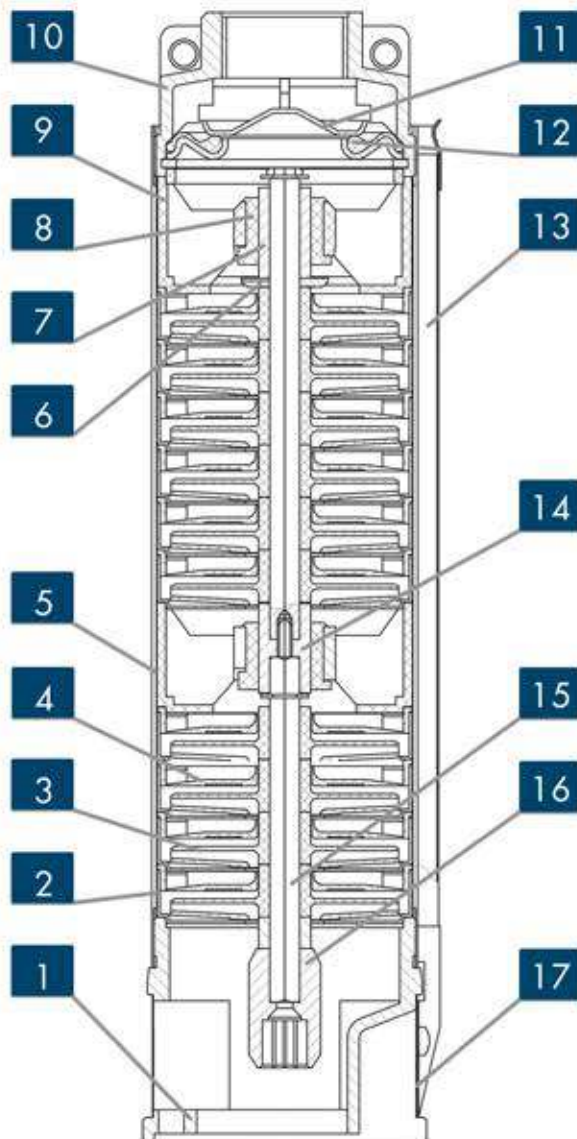

REF.N.	PART	MATERIAL	STANDARD
1	Lower support	Precision-cast stainless steel	AISI 304
2	Stage housing	Stainless steel	AISI 304
3	Impeller	Lexan® PC
4	Diffuser	Lexan® PC
5	Outer sleeve	Stainless steel	AISI 304
6	Thrust bearing	Stainless steel	AISI 304
7	Shaft sleeve	Stainless steel	AISI 304
8	Bush bearing	TPU
9	Upper support	Lexan® PC
10	Delivery port	Precision-cast stainless steel	AISI 304
11	Non-return valve	Stainless steel	AISI 304
12	Valve support with gasket	Stainless steel & NBR	AISI 304 &
13	Cable guard	Stainless steel	AISI 304
14	Intermediate Shaft sleeve	Stainless steel	AISI 304
15	Shaft	Stainless steel	AISI 420
16	Coupling	Stainless steel	AISI 304
17	Filter	Stainless steel	AISI 304



4BH

4BH SERIES

OPERATING CHARACTERISTICS AT 50 Hz

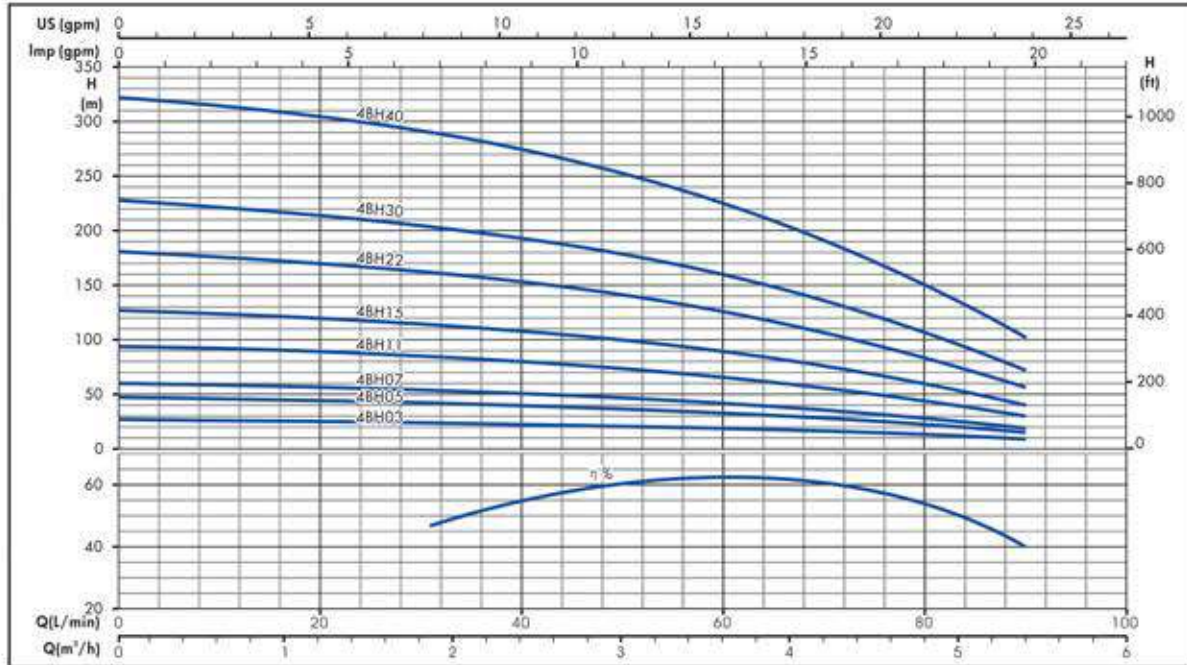

OPERATING CHARACTERISTICS AT 50 Hz

PUMP TYPE	N. OF STAGES	kW	Hp	Q=DELIVERY						
				l/min 0	30	40	50	60	80	90
				m³/h 0	1,8	2,4	3	3,6	4,8	5,4
				H=TOTAL HEAD METERS COLUMN OF WATER						
4BH03S	4	0,37	0,5	27	24	23	21	19	13	9
4BH03T										
4BH05S	7	0,55	0,7	47	42	40	37	33	22	15
4BH05T										
4BH07S	9	0,75	1,0	60	54	51	47	42	28	19
4BH07T										
4BH11S	14	1,1	1,5	94	84	80	74	66	44	30
4BH11T										
4BH15S	19	1,5	2,0	127	114	108	100	89	60	40
4BH15T										
4BH22S	27	2,2	3,0	181	162	154	142	127	85	57
4BH22T										
4BH30T	35	3,0	4,0	228	204	194	179	160	107	72
4BH40T	48	4,0	5,0	322	288	274	252	226	151	102

DIMENSIONS AND WEIGHTS AT 50 Hz

PUMP TYPE	N. OF STAGES	DN	L1 mm	L mm	PUMP Weight Kg	ELECTRIC PUMP Weight Kg
4BH03S	4	Rp1"1/4	254	591	2,2	10,4
4BH03T				596		10
4BH05S	7		319	671	2,8	11,7
4BH05T				676		11,2
4BH07S	9		362	734	3,2	13
4BH07T				739		12,6
4BH11S	14		471	868	4,2	15,3
4BH11T				878		14,9
4BH15S	19		580	1017	5,2	18,2
4BH15T				1027		17,7
4BH22S	27		790	1338	7,4	25,1
4BH22T				1334		24,6
4BH30T	35		964	1568	9	29,5
4BH40T	48		1245	1895	11,6	34,4

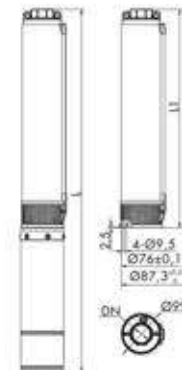

6BH

6BH SERIES

PUMP SECTION AND LIST OF MAIN COMPONENTS MATERIAL

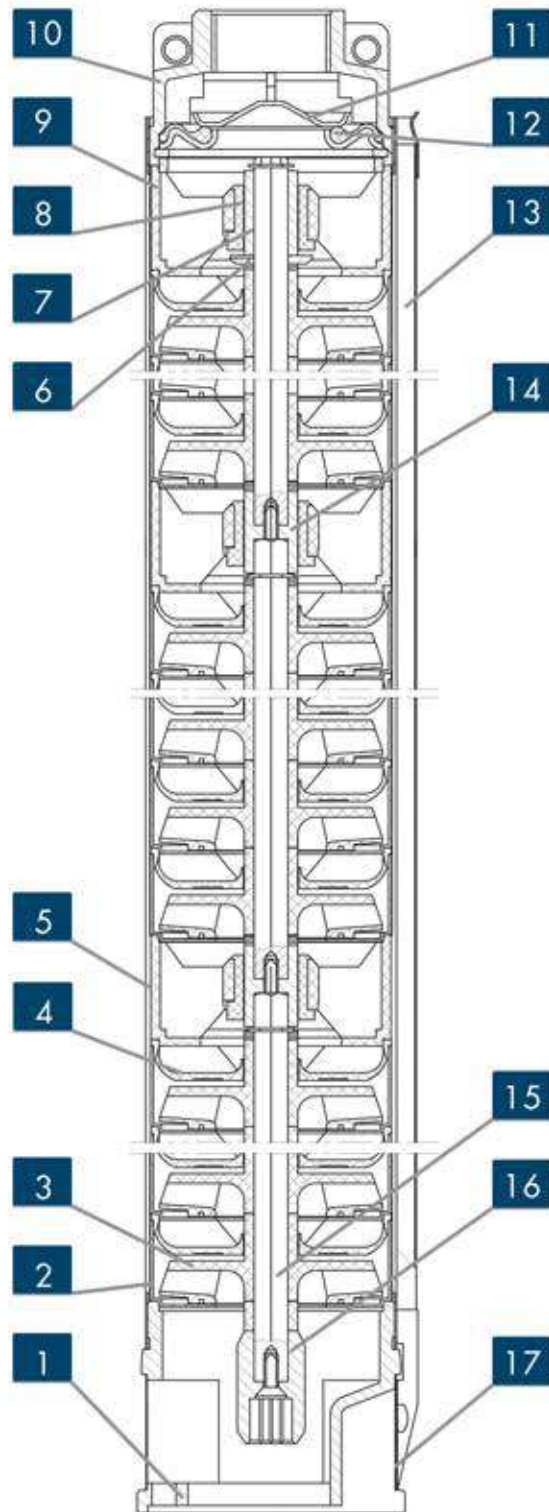

REF.N.	PART	MATERIAL	STANDARD
1	Lower support	Precision-cast stainless steel	AISI 304
2	Stage housing	Stainless steel	AISI 304
3	Impeller	Lexan® PC
4	Diffuser	Lexan® PC
5	Outer sleeve	Stainless steel	AISI 304
6	Thrust bearing	Stainless steel	AISI 304
7	Shaft sleeve	Stainless steel	AISI 304
8	Bush bearing	TPU
9	Upper support	Lexan® PC
10	Delivery port	Precision-cast stainless steel	AISI 304
11	Non-return valve	Stainless steel	AISI 304
12	Valve support with gasket	Stainless steel & NBR	AISI 304 &
13	Cable guard	Stainless steel	AISI 304
14	Intermediate Shaft sleeve	Stainless steel	AISI 304
15	Shaft	Stainless steel	AISI 420
16	Coupling	Stainless steel	AISI 304
17	Filter	Stainless steel	AISI 304



6BH

6BH SERIES

OPERATING CHARACTERISTICS AT 50 Hz

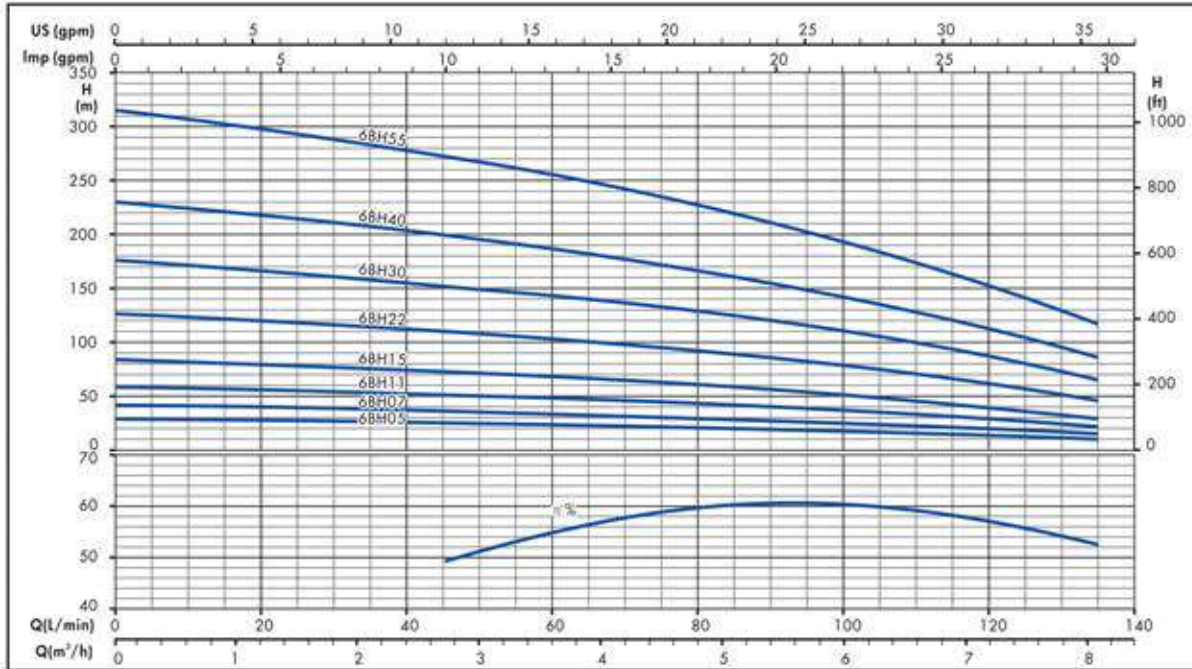

OPERATING CHARACTERISTICS AT 50 Hz

PUMP TYPE	N. OF STAGES	kW	Hp	Q = DELIVERY						
				l/min 0	60	75	90	105	120	135
				m³/h 0	3,6	4,5	5,4	6,3	7,2	8,1
H = TOTAL HEAD METERS COLUMN OF WATER										
6BH05S	5	0,55	0,7	30	25	23	20	18	15	11
6BH05T										
6BH07S	7	0,75	1,0	43	35	32	28	24	20	15
6BH07T										
6BH11S	10	1,1	1,5	61	49	46	41	35	30	22
6BH11T										
6BH15S	14	1,5	2,0	85	69	64	57	50	41	31
6BH15T										
6BH22S	21	2,2	3,0	128	104	97	87	76	61	47
6BH22T										
6BH30T	29	3,0	4,0	177	143	132	119	105	85	66
6BH40T	38	4,0	5,5	232	188	172	156	136	112	86
6BH55T	52	5,5	7,5	317	257	235	213	185	152	118

DIMENSIONS AND WEIGHTS AT 50 Hz

PUMP TYPE	N. OF STAGES	DN	L1 mm	L mm	PUMP Weight Kg	ELECTRIC PUMP Weight Kg
6BH05S	5	Rp1"1/4	332	684	2,8	11,7
6BH05T				689		11,2
6BH07S	7		394	766	3,4	13,2
6BH07T				771		12,8
6BH11S	10		487	884	4,2	15,3
6BH11T				894		14,9
6BH15S	14		611	1048	5,2	18,2
6BH15T				1058		17,7
6BH22S	21		865	1413	7,6	25,3
6BH22T				1409		24,8
6BH30T	29		1113	1717	9,7	30,2
6BH40T	38		1392	2042	12,1	34,9
6BH55T	52		1863	2633	16,3	44,7

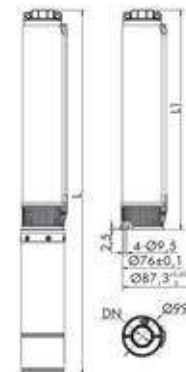

8BH

8BH SERIES

PUMP SECTION AND LIST OF MAIN COMPONENTS MATERIAL

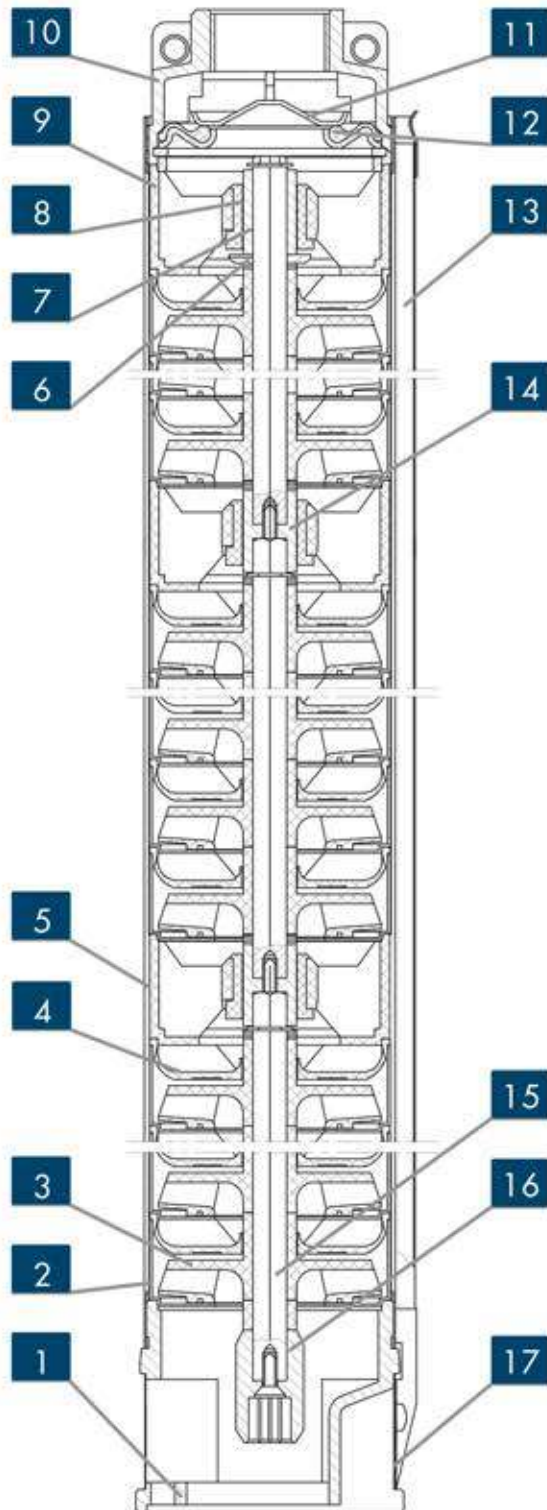

REF.N.	PART	MATERIAL	STANDARD
1	Lower support	Precision-cast stainless steel	AISI 304
2	Stage housing	Stainless steel	AISI 304
3	Impeller	Lexan® PC
4	Diffuser	Lexan® PC
5	Outer sleeve	Stainless steel	AISI 304
6	Thrust bearing	Stainless steel	AISI 304
7	Shaft sleeve	Stainless steel	AISI 304
8	Bush bearing	TPU
9	Upper support	Lexan® PC
10	Delivery port	Precision-cast stainless steel	AISI 304
11	Non-return valve	Stainless steel	AISI 304
12	Valve support with gasket	Stainless steel & NBR	AISI 304 &
13	Cable guard	Stainless steel	AISI 304
14	Intermediate Shaft sleeve	Stainless steel	AISI 304
15	Shaft	Stainless steel	AISI 420
16	Coupling	Stainless steel	AISI 304
17	Filter	Stainless steel	AISI 304



8BH

8BH SERIES

OPERATING CHARACTERISTICS AT 50 Hz

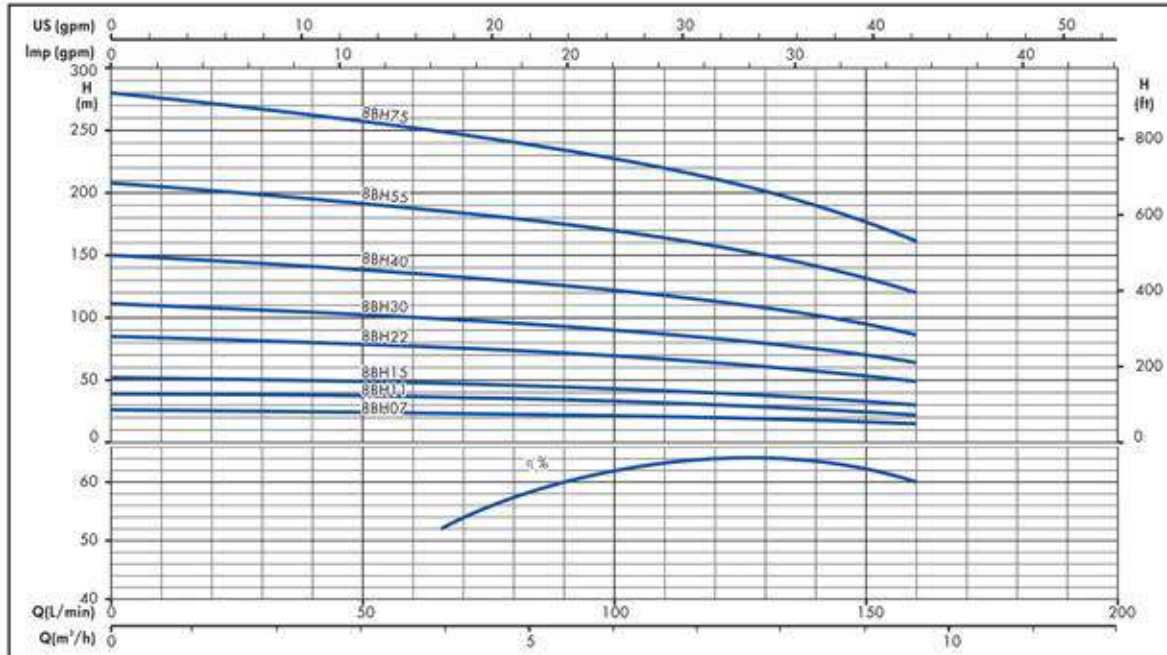

OPERATING CHARACTERISTICS AT 50 Hz

PUMP TYPE	N.OF STAGES	kW	Hp	Q=DELIVERY						
				l/min 0	60	80	100	120	140	160
				m³/h 0						
				3,6	4,8	6	7,2	8,4	9,6	
H=TOTAL HEAD METERS COLUMN OF WATER										
8BH07S	4	0,75	1,0	26	23	22	21	20	18	15
8BH07T										
8BH11S	6	1,1	1,5	39	35	34	32	29	27	22
8BH11T										
8BH15S	8	1,5	2,0	52	47	45	43	39	35	30
8BH15T										
8BH22S	13	2,2	3,0	85	76	73	69	64	57	49
8BH22T										
8BH30S	17	3,0	4,0	111	100	95	90	83	75	64
8BH40S	23	4,0	5,5	150	135	129	122	113	102	86
8BH55S	32	5,5	7,5	208	187	179	170	157	141	120
8BH75S	43	7,5	10	280	252	241	228	211	190	161

DIMENSIONS AND WEIGHTS AT 50 Hz

PUMP TYPE	N.OF STAGES	DN	LT mm	L mm	PUMP Weight Kg	ELECTRIC PUMP Weight Kg
8BH07S	4	Rp2"	301	673	2,7	12,5
8BH07T				678		12,1
8BH11S	6		363	760	3,2	14,3
8BH11T				770		13,9
8BH15S	8		425	862	3,8	16,8
8BH15T				872		16,3
8BH22S	13		580	1128	5,2	22,9
8BH22T				1124		22,4
8BH30S	17		704	1308	6,3	26,8
8BH40S	23		927	1577	8,4	31,2
8BH55S	32		1206	1976	11	39,4
8BH75S	43		1584	2469	14,5	48,6

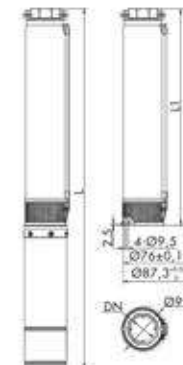

12BH

12BH SERIES

PUMP SECTION AND LIST OF MAIN COMPONENTS MATERIAL

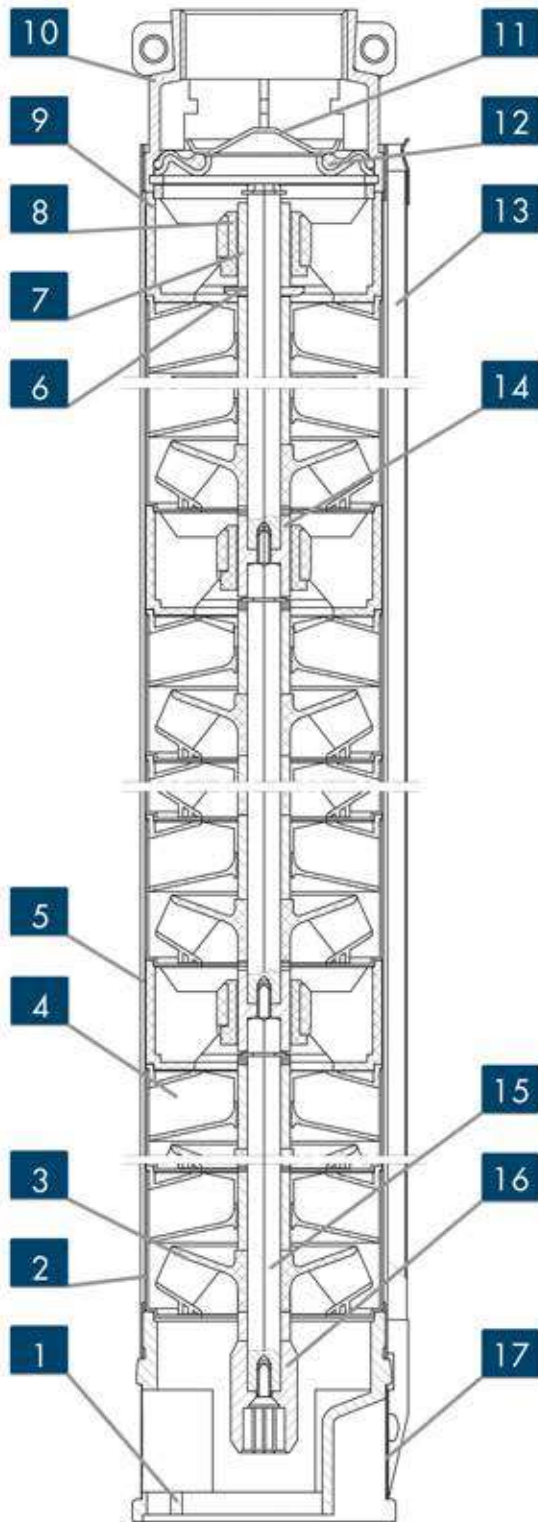

REF.N.	PART	MATERIAL	STANDARD
1	Lower support	Precision-cast stainless steel	AISI 304
2	Stage housing	Stainless steel	AISI 304
3	Impeller	Lexan® PC
4	Diffuser	Lexan® PC
5	Outer sleeve	Stainless steel	AISI 304
6	Thrust bearing	Stainless steel	AISI 304
7	Shaft sleeve	Stainless steel	AISI 304
8	Bush bearing	TPU
9	Upper support	Lexan® PC
10	Delivery port	Precision-cast stainless steel	AISI 304
11	Non-return valve	Stainless steel	AISI 304
12	Valve support with gasket	Stainless steel & NBR	AISI 304 &
13	Cable guard	Stainless steel	AISI 304
14	Intermediate Shaft sleeve	Stainless steel	AISI 304
15	Shaft	Stainless steel	AISI 420
16	Coupling	Stainless steel	AISI 304
17	Filter	Stainless steel	AISI 304



12BH

12BH SERIES

OPERATING CHARACTERISTICS AT 50 Hz

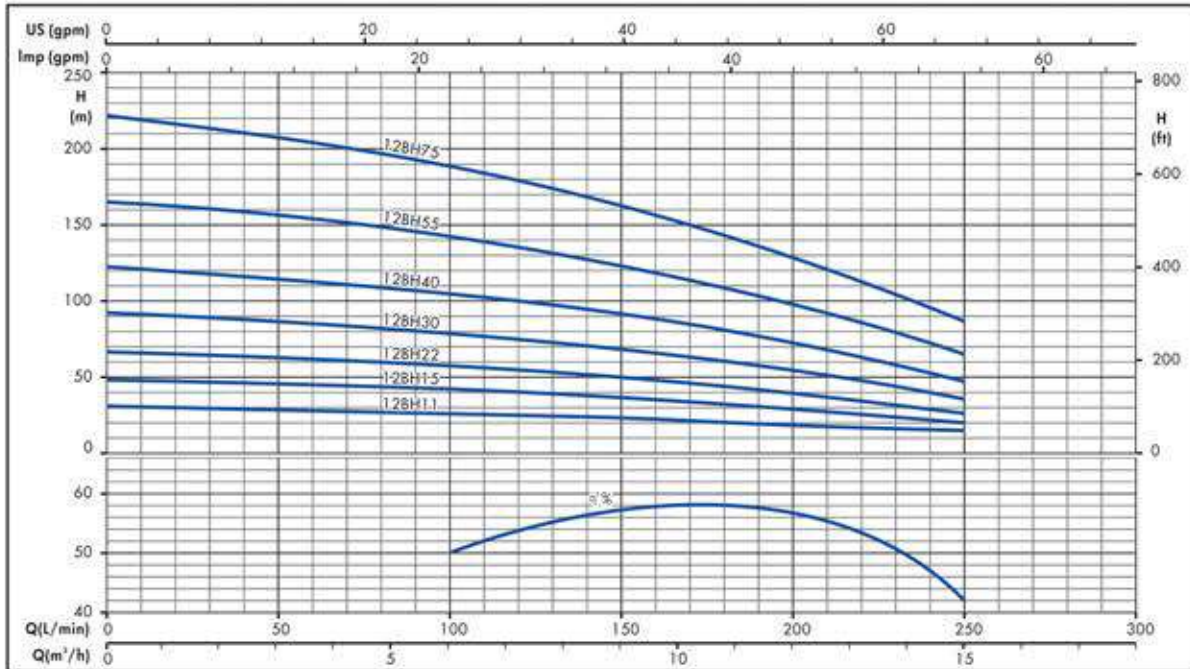

OPERATING CHARACTERISTICS AT 50 Hz

PUMP TYPE	N. OF STAGES	kW	Hp	Q=DELIVERY							
				l/min Ø	100	120	140	160	200	250	
				m³/h Ø							
				6	7,2	8,4	9,6	12	15		
				H=TOTAL HEAD METERS COLUMN OF WATER							
12BH115	5	1,1	1,5	31	26	25	24	21	18	12	
12BH11T											
12BH155	8	1,5	2,0	49	42	40	38	34	29	19	
12BH15T											
12BH225	11	2,2	3,0	67	58	55	52	47	40	26	
12BH22T											
12BH30T	15	3,0	4,0	92	79	75	71	65	54	36	
12BH40T	20	4,0	5,5	122	105	100	94	87	72	48	
12BH55T	27	5,5	7,5	165	142	135	127	117	98	65	
12BH75T	36	7,5	10	221	189	180	169	156	130	87	

DIMENSIONS AND WEIGHTS AT 50 Hz

PUMP TYPE	N. OF STAGES	DN	L1 mm	L mm	PUMP Weight Kg	ELECTRIC PUMP Weight Kg
12BH115	5	Rp2"	437	831	3,2	14,3
12BH11T				841		13,9
12BH155	8		593	1030	4,7	17,7
12BH15T				1040		17,2
12BH225	11		749	1297	6,1	23,8
12BH22T				1293		23,3
12BH30T	15		994	1598	8,5	29
12BH40T	20		1254	1904	10,8	33,6
12BH55T	27		1655	2425	14,7	43,1
12BH75T	36		2123	3008	19	53

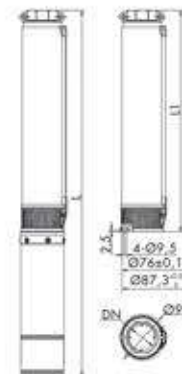

16BH

16BH SERIES

PUMP SECTION AND LIST OF MAIN COMPONENTS MATERIAL

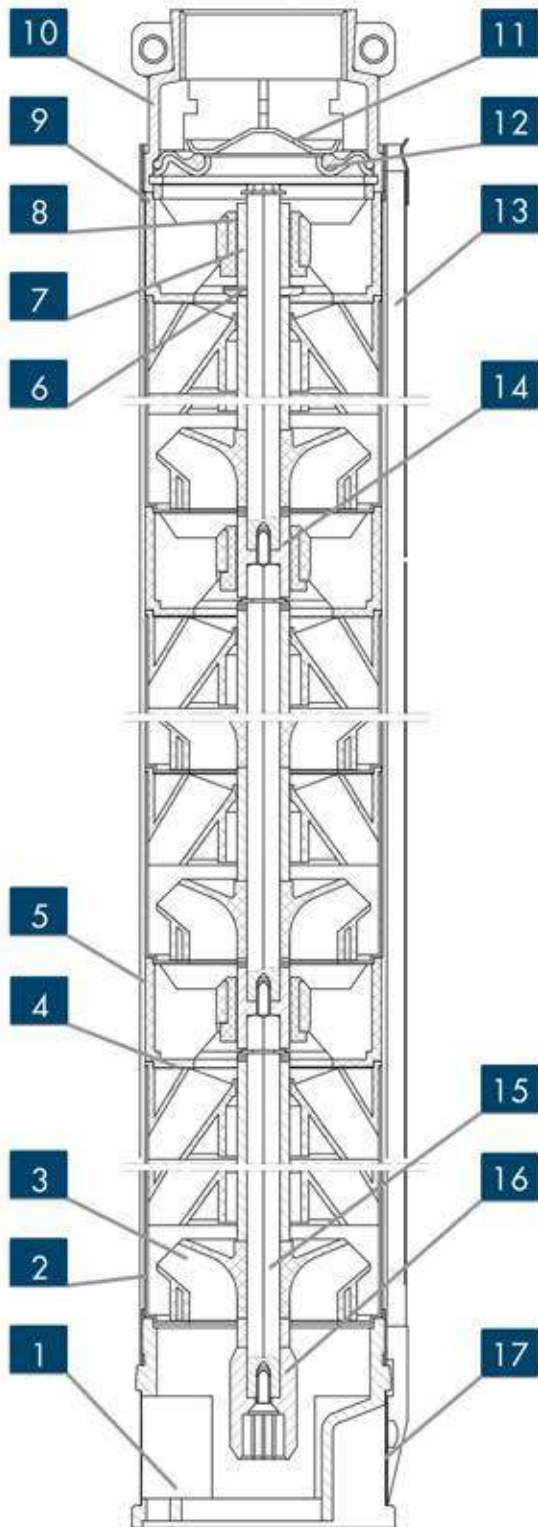

REF.N.	PART	MATERIAL	STANDARD
1	Lower support	Precision-cast stainless steel	AISI 304
2	Stage housing	Stainless steel	AISI 304
3	Impeller	Lexan® PC
4	Diffuser	Lexan® PC
5	Outer sleeve	Stainless steel	AISI 304
6	Thrust bearing	Stainless steel	AISI 304
7	Shaft sleeve	Stainless steel	AISI 304
8	Bush bearing	TPU
9	Upper support	Lexan® PC
10	Delivery port	Precision-cast stainless steel	AISI 304
11	Non-return valve	Stainless steel	AISI 304
12	Valve support with gasket	Stainless steel & NBR	AISI 304 &
13	Cable guard	Stainless steel	AISI 304
14	Intermediate Shaft sleeve	Stainless steel	AISI 304
15	Shaft	Stainless steel	AISI 420
16	Coupling	Stainless steel	AISI 304
17	Filter	Stainless steel	AISI 304



16BH

16BH SERIES

OPERATING CHARACTERISTICS AT 50 Hz

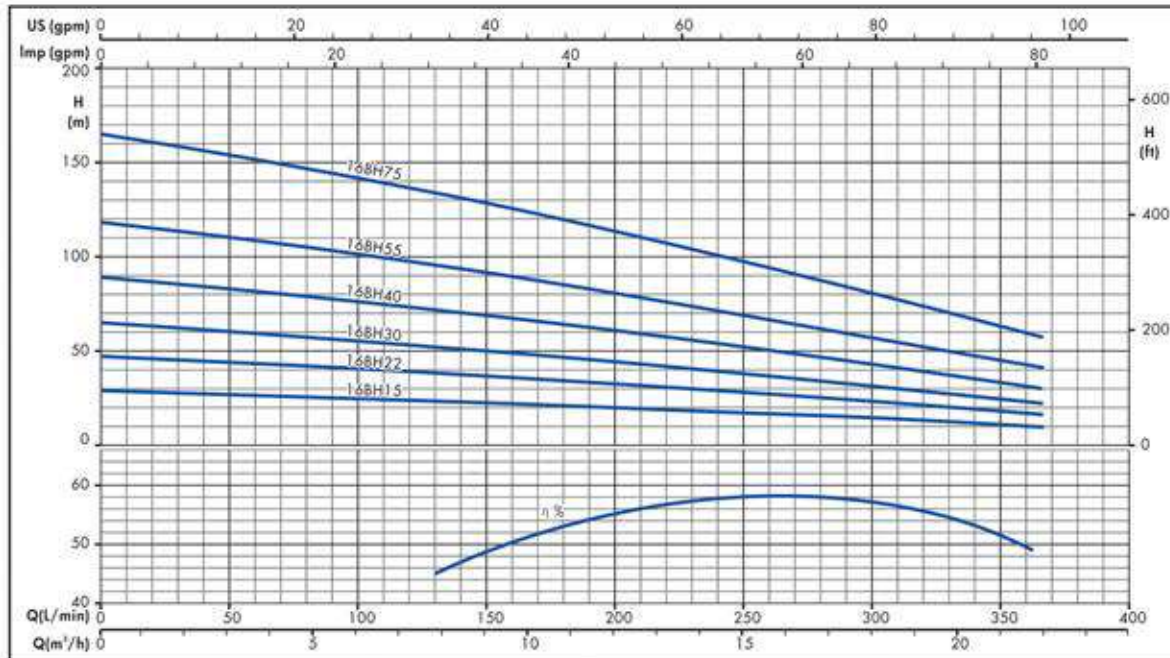

OPERATING CHARACTERISTICS AT 50 Hz

PUMP TYPE	N. OF STAGES	kW	Hp	Q=DELIVERY						
				l/min 0	140	160	200	250	300	367
				m³/h 0	8,4	9,6	12	15	18	22
H=TOTAL HEAD METERS COLUMN OF WATER										
16BH15S	5	1,5	2,0	29	23	22	20	17	14	10
16BH15T										
16BH22S	8	2,2	3,0	47	37	36	32	27	23	16
16BH22T										
16BH30T	11	3,0	4,0	65	51	49	44	38	31	22
16BH40T	15	4,0	5,5	89	70	67	60	51	43	30
16BH55T	20	5,5	7,5	118	97	89	80	69	57	41
16BH75T	28	7,5	10	165	131	125	112	96	80	57

DIMENSIONS AND WEIGHTS AT 50 Hz

PUMP TYPE	N. OF STAGES	DN	L1 mm	L mm	PUMP Weight Kg	ELECTRIC PUMP Weight Kg
16BH15S	5	Rp2"	517	951	4,1	17,1
16BH15T				961		16,6
16BH22S	8		721	1269	6,0	23,7
16BH22T				1265		23,2
16BH30T	11		962	1566	8,4	28,9
16BH40T	15		1234	1884	10,9	33,7
16BH55T	20		1611	2381	13,7	42,1
16BH75T	28	2155	3040	18,8	52,9	



BP

BP SERIES 6" SUBMERSIBLE PUMPS

- Made completely of corrosion-resistant AISI 304 stainless steel, BP pumps are ideal for a wide variety of applications with high efficiency and reliability.

APPLICATIONS

- Water supply from deep well
- Agriculture irrigation
- Pressure boosting
- Fire-fighting
- Industrial application

SPECIFICATIONS

- Delivery: up to 85 m³/h at 2850 rpm.
- Head: up to 500 m at 2850 rpm.
- Maximum overall diameter of pump: 143 mm (one cable guard included).
- Maximum permissible quantity of suspended sand: 150 g/m³.
- Standard delivery port: Rp 3".

MOTOR

- Motor power: from 3,0 to 30 kW, 380 V, 50 Hz.

CONSTRUCTION CHARACTERISTICS

- Sturdy and lightweight, easy to maintain and resistant to corrosion in non-aggressive environments.
- High efficient hydraulic design for cost saving and best performance.
- Stainless steel built-in non-return valve.
- Stainless steel impellers and diffusers.
- Stainless steel delivery port and suction support.
- Stainless steel shaft and replaceable coupling.
- PTFE floating wear ring, octagonal bearings and sand flush channel ensure maximum resistance to wear and long-lasting performance and reliability.
- Coupling and flange mounting dimensions meet NEMA standards.

OPTIONAL FEATURES

- Different voltages and frequencies.
- Delivery port: Rp4".



BP

BP SERIES

HYDRAULIC PERFORMANCE RANGE AT 50 Hz

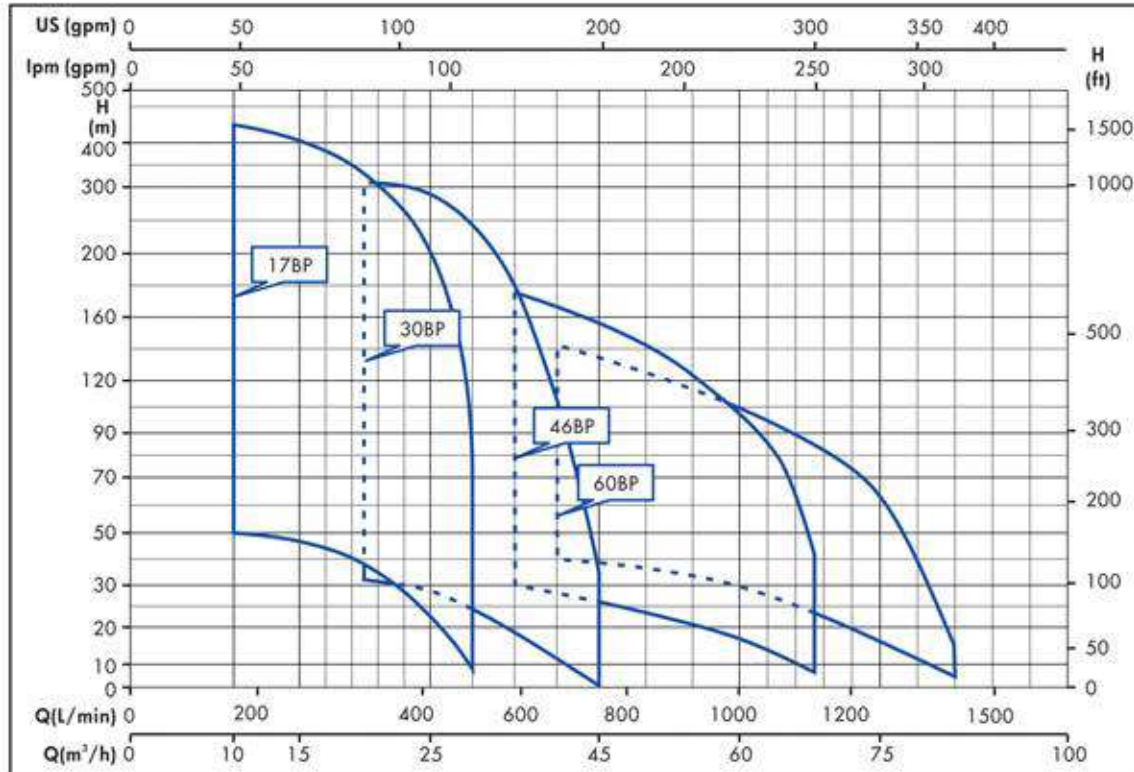

IDENTIFICATION CODE

17	BP	6	75
----	----	---	----

- 17: FLOW RATE IN m³/h
- BP: BP SERIES 6" SUBMERSIBLE PUMPS
- 6: 6" MOTOR
- 75: MOTOR POWER IN kW x 10

EXAMPLE OF PUMP TYPE

17BP675

BP series submersible pump, flow rate 17 m³/h, coupled to a 6" submersible motor 7,5 kW (10 Hp).



17BP

17BP SERIES

PUMP SECTION AND LIST OF MAIN COMPONENTS MATERIAL

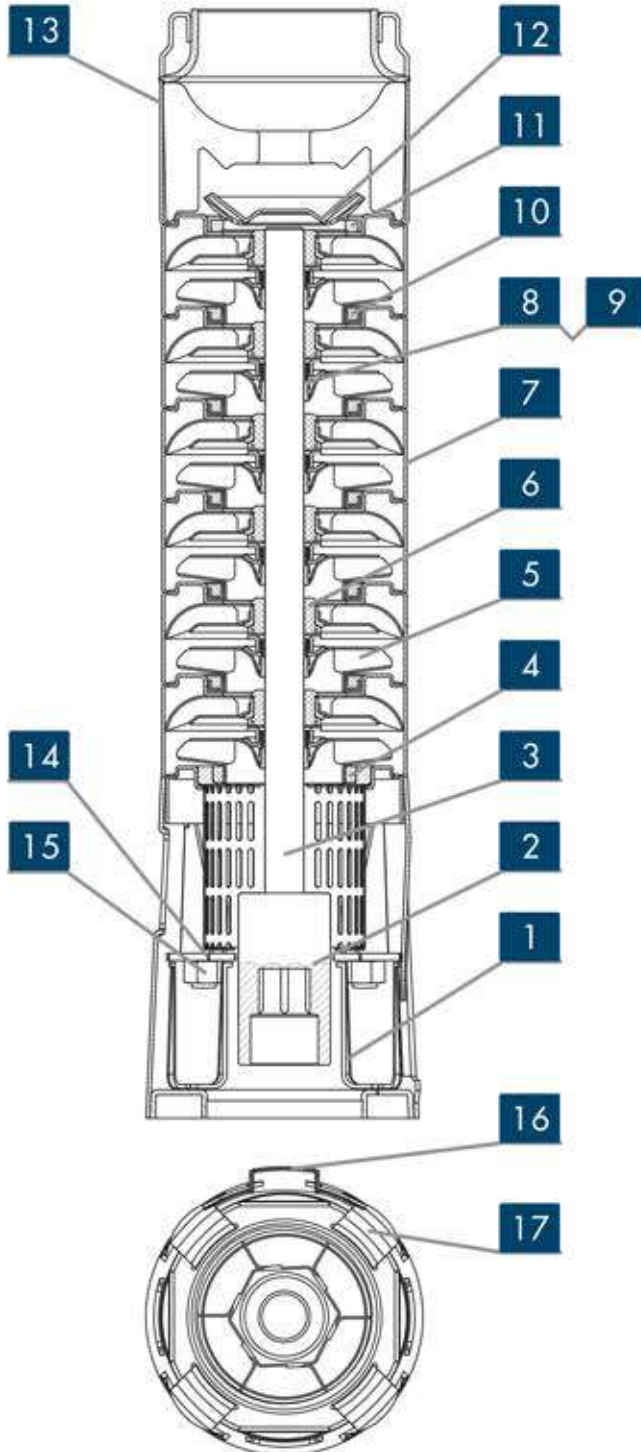

REF.N.	PART	MATERIAL	STANDARD
1	Lower support	Stainless steel	AISI 304
2	Coupling	Stainless steel	AISI 304
3	Shaft	Stainless steel	AISI 304
4	First neck ring	Carbon/graphite In PTFE
5	Impeller	Stainless steel	AISI 304
6	Bush bearing	NBR
7	Diffuser	Stainless steel	AISI 304
8	Split cone	Stainless steel	AISI 304
9	Split cone nut	Stainless steel	AISI 304
10	Neck ring	NBR
11	Valve support	NBR
12	Non-return valve	Stainless steel	AISI 304
13	Delivery port	Stainless steel	AISI 304
14	Washer	Stainless steel	AISI 304
15	Nut for strap	Stainless steel	AISI 304
16	Cable guard	Stainless steel	AISI 304
17	Strap	Stainless steel	AISI 304



17BP

17BP SERIES

OPERATING CHARACTERISTICS AT 50 Hz

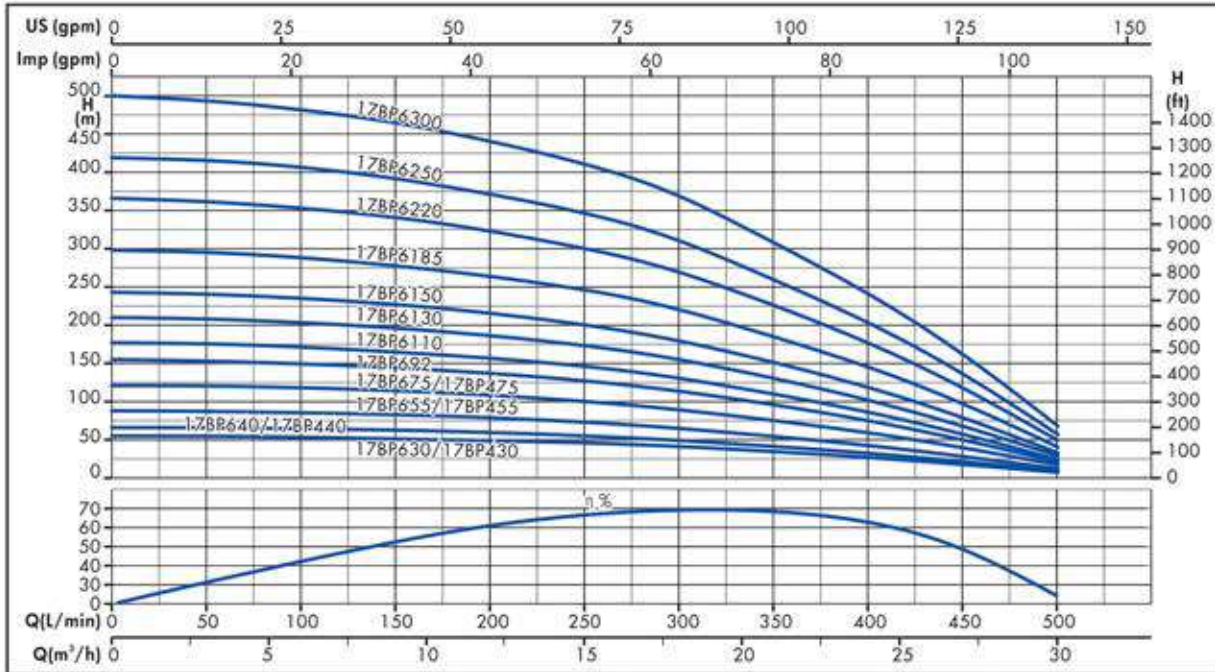

OPERATING CHARACTERISTICS AT 50 Hz

PUMP TYPE	N. OF STAGES	kW	Hp	Q=DELIVERY									
				L/min 0	83	167	250	283	333	417	500		
				m³/h 0 5 10 15 17 20 25 30									
				H=TOTAL HEAD METERS COLUMN OF WATER									
17BP430	5	3,0	4,0	55	54	50	46	43	37	24	8		
17BP440	6	4,0	6,0	66	65	60	55	51	44	29	9		
17BP455	8	5,5	7,5	88	86	80	73	68	58	38	12		
17BP475	11	7,5	10	121	119	110	100	94	80	53	17		
17BP625	14	9,2	12,5	155	151	140	127	119	102	67	21		
17BP6110	16	11	15	177	173	160	146	136	117	77	24		
17BP6130	19	13	17,5	210	205	190	173	162	139	91	29		
17BP6150	22	15	20	243	237	220	200	187	161	106	33		
17BP6185	27	18,5	25	298	291	270	246	230	197	130	41		
17BP6220	33	22	30	364	356	330	300	281	241	158	50		
17BP6250	38	25	35	419	410	380	346	323	277	182	57		
17BP6300	45	30	40	500	486	450	410	383	329	216	68		

DIMENSIONS AND WEIGHTS AT 50 Hz

PUMP TYPE	N. OF STAGE	DN	L mm	PUMP WEIGHT kg
17BP630	5	Rp3"	497	8,7
17BP430			472	8,3
17BP640			542	9,6
17BP440	517		9,2	
17BP655	656		11,4	
17BP455	681		11	
17BP675	741		14,1	
17BP475	766		4,2	
17BP692	901		16,8	
17BP6110	991		18,6	
17BP6130	1126		21,3	
17BP6150	1261		24	
17BP6185	1486		28,5	
17BP6220	1756		33,9	
17BP6250	1981		38,4	
17BP6300	2226	44,7		



30BP

30BP SERIES

PUMP SECTION AND LIST OF MAIN COMPONENTS MATERIAL

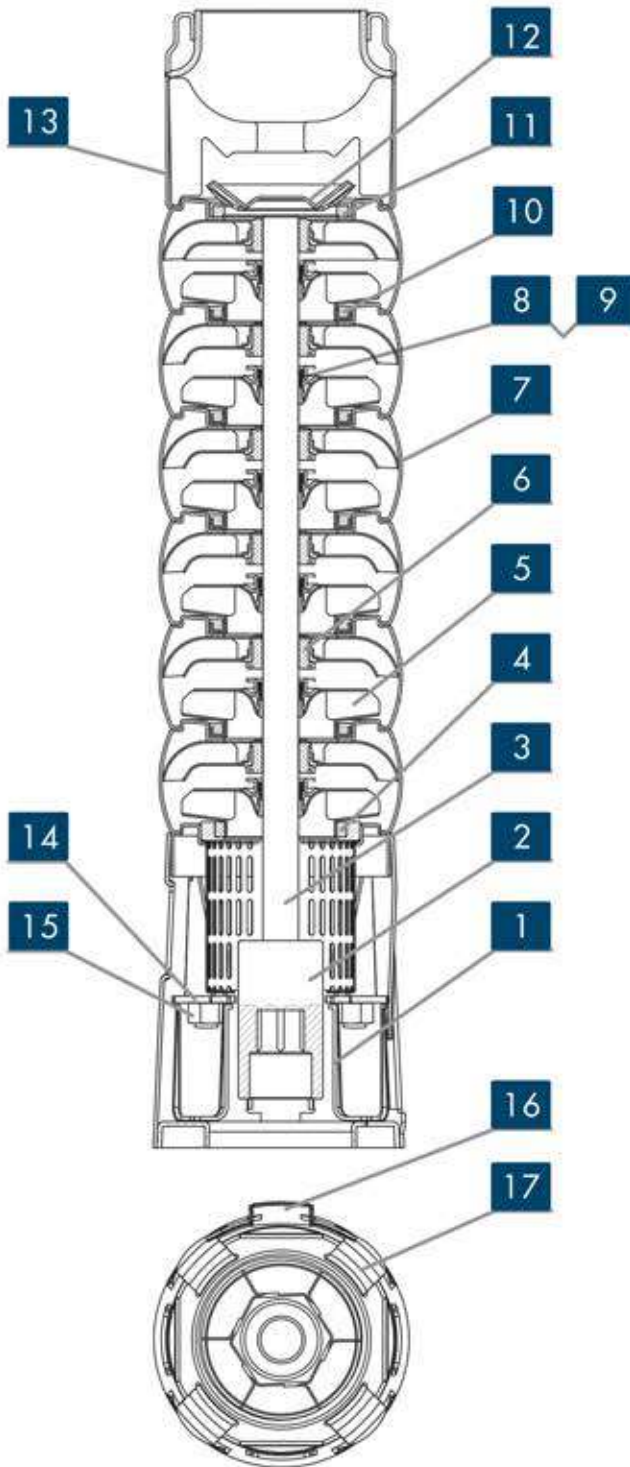

REF.N.	PART	MATERIAL	STANDARD
1	Lower support	Stainless steel	AISI 304
2	Coupling	Stainless steel	AISI 304
3	Shaft	Stainless steel	AISI 304
4	First neck ring	Carbon/graphite In PTFE
5	Impeller	Stainless steel	AISI 304
6	Bush bearing	NBR
7	Diffuser	Stainless steel	AISI 304
8	Split cone	Stainless steel	AISI 304
9	Split cone nut	Stainless steel	AISI 304
10	Neck ring	NBR
11	Valve support	NBR
12	Non-return valve	Stainless steel	AISI 304
13	Delivery port	Stainless steel	AISI 304
14	Washer	Stainless steel	AISI 304
15	Nut for strap	Stainless steel	AISI 304
16	Cable guard	Stainless steel	AISI 304
17	Strap	Stainless steel	AISI 304



30BP

30BP SERIES

OPERATING CHARACTERISTICS AT 50 Hz

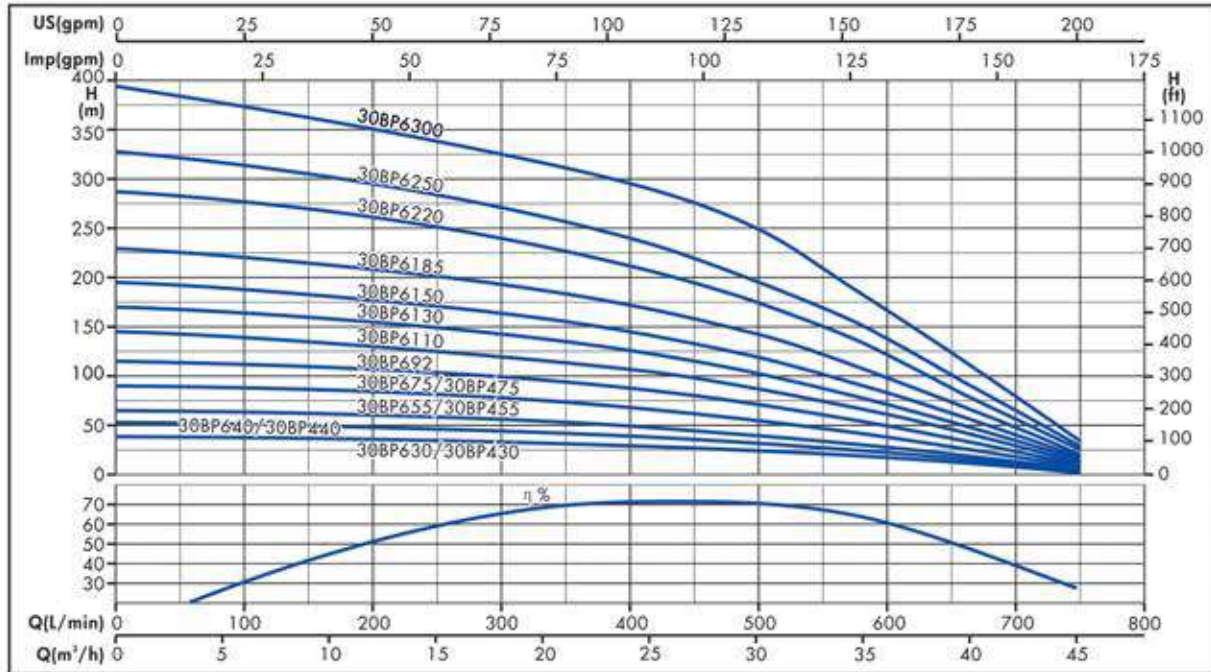

OPERATING CHARACTERISTICS AT 50 Hz

PUMP TYPE	NO. OF STAGES	kW	Hp	Q = DELIVERY							
				L/min	167	333	417	500	583	667	750
				H = TOTAL HEAD METERS COLUMN OF WATER							
30BP430	3	3,0	4,0	39	36	32	28	24	18	11	3
30BP630				10	20	25	30	35	40	45	
30BP440	4	4,0	6,0	52	48	42	38	32	24	14	4
30BP640				10	20	25	30	35	40	45	
30BP455	5	6,0	8,0	64	60	53	47	40	30	18	6
30BP655				10	20	25	30	35	40	45	
30BP475	7	8,0	10	90	84	74	66	55	42	25	8
30BP675				10	20	25	30	35	40	45	
30BP692	9	9,2	12,5	116	108	95	85	70	54	32	10
30BP6110	11	11	15	144	132	116	103	86	66	40	12
30BP6130	13	13	17,5	170	156	137	122	102	78	47	14
30BP6150	15	15	20	197	180	158	141	120	90	54	17
30BP6185	18	18,5	25	236	215	189	169	147	108	65	20
30BP6220	22	22	30	288	263	231	207	175	132	79	24
30BP6250	25	25	35	328	299	263	235	195	150	90	28
30BP6300	30	30	40	393	359	315	282	235	180	108	33

DIMENSIONS AND WEIGHTS AT 50 Hz

PUMP TYPE	N. OF STAGE	DN	L mm	PUMP WEIGHT kg
30BP630	3	Rp3"	441,5	7,2
30BP430			416,5	6,8
30BP640	4		498	8,2
30BP440			473	7,8
30BP655	5		554	9,2
30BP455			529	8,8
30BP675	7		667	11,2
30BP475			642	10,8
30BP692	9		780	13,2
30BP6110	11		893	15,2
30BP6130	13		1006	17,2
30BP6150	15		1119	19,2
30BP6185	18		1288	22,2
30BP6220	22		1514	26,2
30BP6250	25	1684	29,2	
30BP6300	30	1966	34,2	

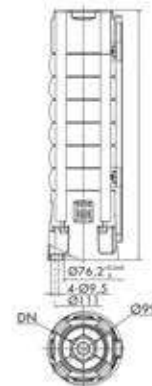

46BP

46BP SERIES

PUMP SECTION AND LIST OF MAIN COMPONENTS MATERIAL

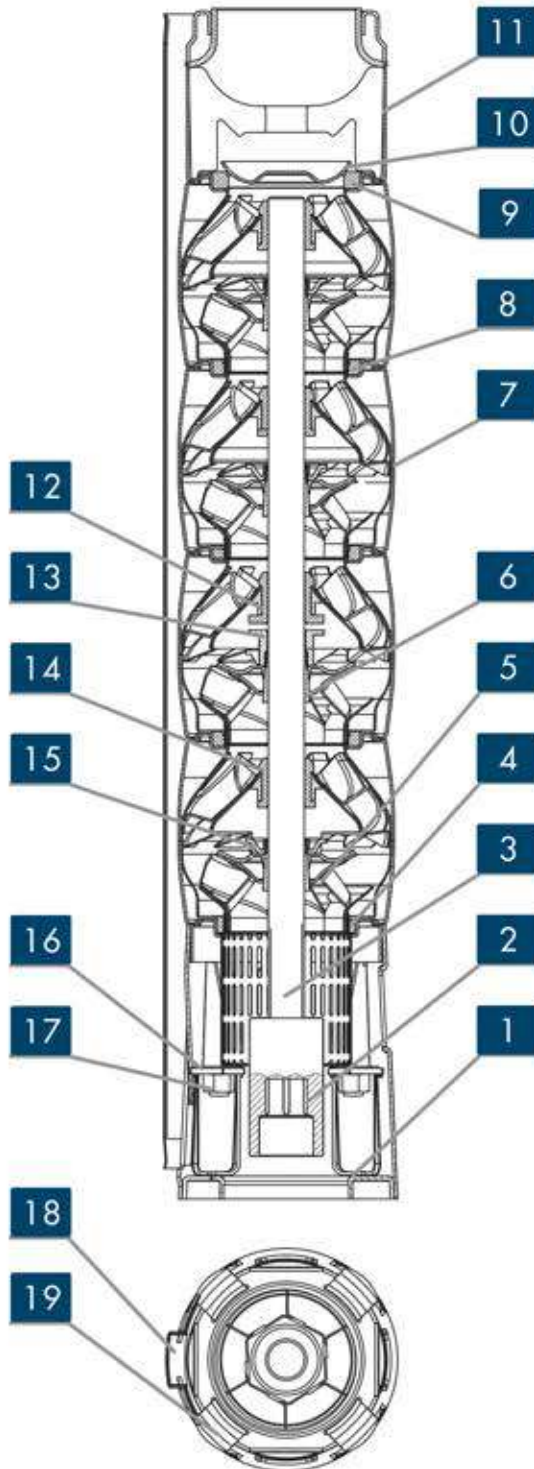

REF.N.	PART	MATERIAL	STANDARD
1	Lower support	Stainless steel	AISI 304
2	Coupling	Stainless steel	AISI 304
3	Shaft	Stainless steel	AISI 304
4	First neck ring	Carbon/graphite in PTFE	-----
5	Impeller	Stainless steel	AISI 304
6	Split cone	Stainless steel	AISI 304
7	Diffuser	Stainless steel	AISI 304
8	Neck ring	NBR	-----
9	Valve support	NBR	-----
10	Non-return valve	Stainless steel	AISI 304
11	Delivery port	Stainless steel	AISI 304
12	Thrust bearing	NBR	-----
13	Nut for stop ring	Stainless steel	AISI 304
14	Bush bearing	NBR	-----
15	Split cone nut	Stainless steel	AISI 304
16	Washer	Stainless steel	AISI 304
17	Nut for strap	Stainless steel	AISI 304
18	Cable guard	Stainless steel	AISI 304
19	Strap	Stainless steel	AISI 304



46BP

46BP SERIES

OPERATING CHARACTERISTICS AT 50 Hz

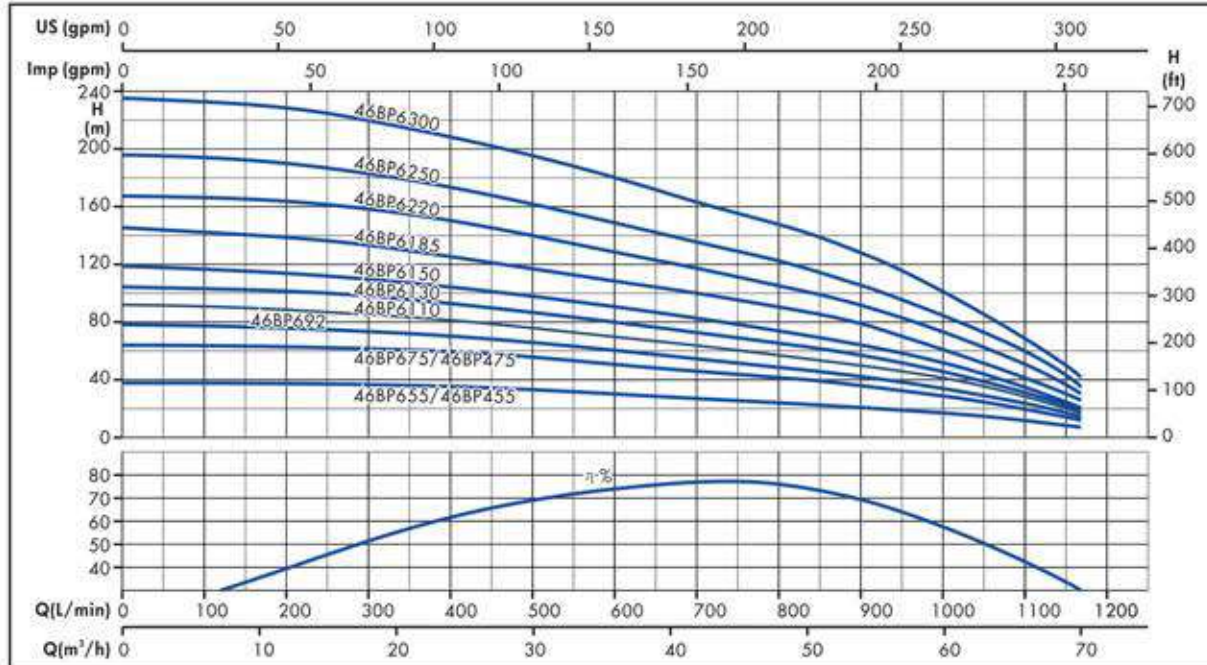

OPERATING CHARACTERISTICS AT 50 Hz

PUMP TYPE	N. OF STAGES	kW	Hp	Q = DELIVERY												
				L/min 0	167	333	583	667	767	833	917	1000	1083	1167		
				m³/h 0 10 20 30 40 50 60 70												
				H = TOTAL HEAD METERS COLUMN OF WATER												
46BP455	3	5,5	7,5	38	38	36	30	28	26	23	21	17	12	7		
46BP655				46BP475	46BP675	5	7,5	10	64	64	60	50	47	43	40	35
46BP692	6	9,2	12,5	78	77	72	59	56	51	47	42	34	25	14		
46BP6110	7	11	15	91	89	84	70	66	61	56	49	41	30	17		
46BP6130	8	13	17,5	104	102	96	79	74	68	63	56	45	33	19		
46BP6150	9	15	20	117	115	108	89	84	77	71	63	50	37	21		
46BP6185	11	18,5	25	145	141	131	110	104	93	88	76	60	45	26		
46BP6220	13	22	30	169	166	155	129	121	111	103	90	73	54	31		
46BP6250	15	25	35	195	192	179	149	140	128	117	104	84	62	35		
46BP6300	18	30	40	234	230	215	175	167	153	142	125	101	75	42		

DIMENSIONS AND WEIGHTS AT 50 Hz

PUMP TYPE	N. OF STAGE	DN	L mm	PUMP WEIGHT kg
46BP655	3	Rp3"/Rp4"	610	11
46BP455			585	10,6
46BP675	5		836	15,5
46BP475			811	15,1
46BP692	6		949	17,7
46BP6110	7		1062	20
46BP6130	8		1175	22,2
46BP6150	9		1288	24,5
46BP6185	11		1514	29
46BP6220	13		1740	33,5
46BP6250	15		1966	38
46BP6300	18		2305	44,7

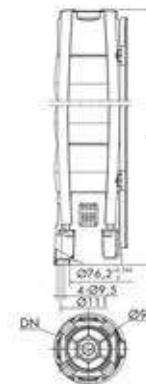

60BP

60BP SERIES

PUMP SECTION AND LIST OF MAIN COMPONENTS MATERIAL

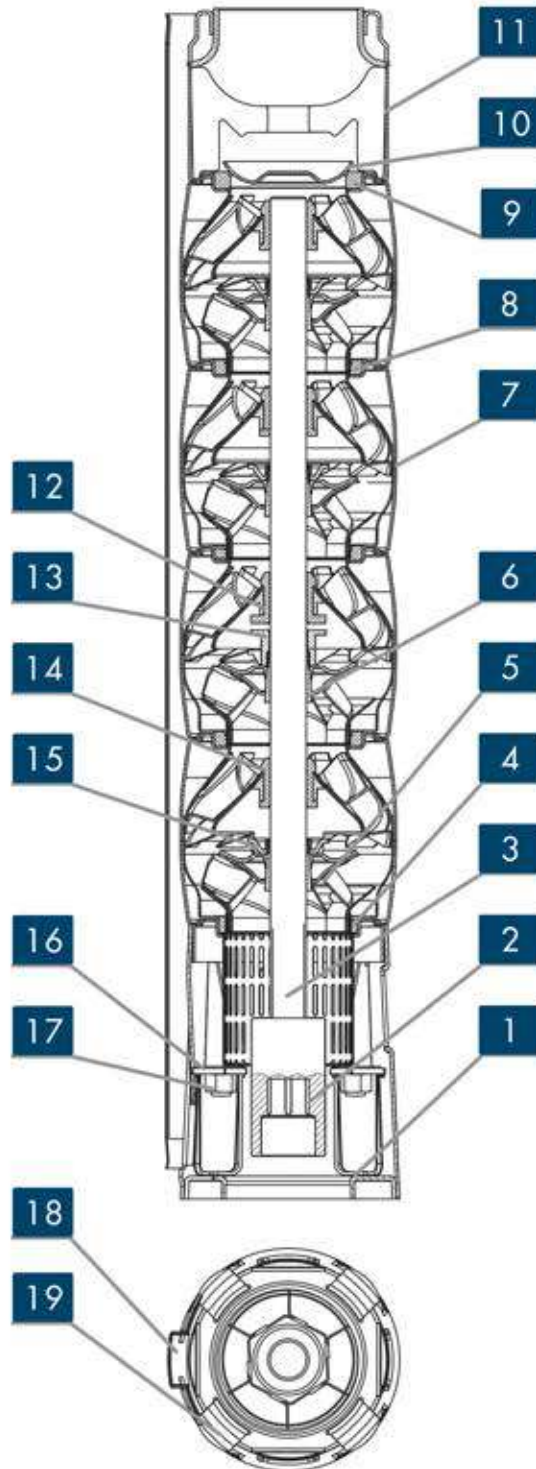

REF.N.	PART	MATERIAL	STANDARD
1	Lower support	Stainless steel	AISI 304
2	Coupling	Stainless steel	AISI 304
3	Shaft	Stainless steel	AISI 304
4	First neck ring	Carbon/graphite in PTFE	-----
5	Impeller	Stainless steel	AISI 304
6	Split cone	Stainless steel	AISI 304
7	Diffuser	Stainless steel	AISI 304
8	Neck ring	NBR	-----
9	Valve support	NBR	-----
10	Non-return valve	Stainless steel	AISI 304
11	Delivery port	Stainless steel	AISI 304
12	Thrust bearing	NBR	-----
13	Nut for stop ring	Stainless steel	AISI 304
14	Bush bearing	NBR	-----
15	Split cone nut	Stainless steel	AISI 304
16	Washer	Stainless steel	AISI 304
17	Nut for strap	Stainless steel	AISI 304
18	Cable guard	Stainless steel	AISI 304
19	Strap	Stainless steel	AISI 304



60BP

60BP SERIES

OPERATING CHARACTERISTICS AT 50 Hz

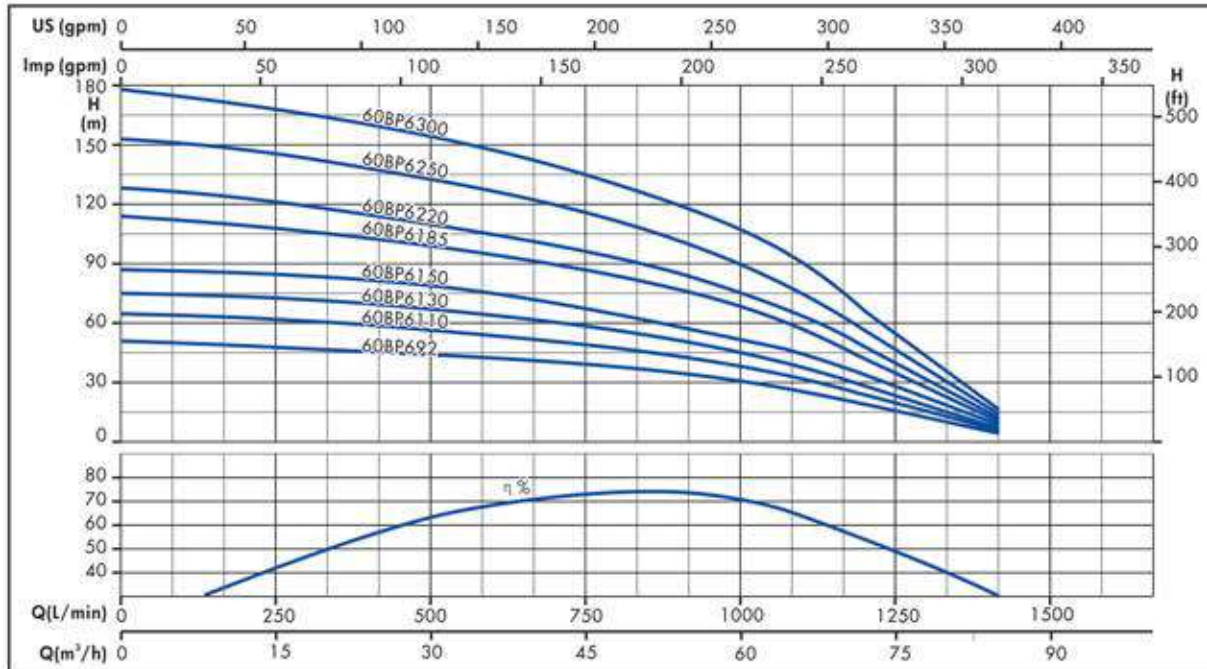

OPERATING CHARACTERISTICS AT 50 Hz

PUMP TYPE	N.OF STAGES	kW	Hp	Q = DELIVERY											
				L/min 0	667	767	833	917	1000	1083	1200	1333	1417		
				m³/h 0	40	46	50	55	60	65	72	80	85		
H = TOTAL HEAD METERS COLUMN OF WATER															
60BP692	4	9,2	12,5	51	40	39	36	34	30	26	18	11	5		
60BP6110	5	11	15	64	51	48	45	42	38	33	23	13	6		
60BP6130	6	13	17,5	77	61	58	54	50	45	39	27	16	7		
60BP6150	7	15	20	89	71	68	63	59	52	46	32	19	8		
60BP6185	9	18,5	25	115	91	87	81	76	68	59	41	24	10		
60BP6220	10	22	30	128	101	97	90	84	75	65	45	26	12		
60BP6250	12	25	35	153	121	116	108	101	90	78	54	31	14		
60BP6300	14	30	40	179	141	135	126	118	105	91	63	36	16		

DIMENSIONS AND WEIGHTS AT 50 Hz

PUMP TYPE	N.OF STAGES	DN	L mm	PUMP WEIGHT kg
60BP692	4	Rp3"/Rp4"	723	13,4
60BP6110	5		836	15,8
60BP6130	6		949	18,1
60BP6150	7		1062	20,4
60BP6185	9		1288	25
60BP6220	10		1401	27,3
60BP6250	12		1627	31,9
60BP6300	14		1853	36,5

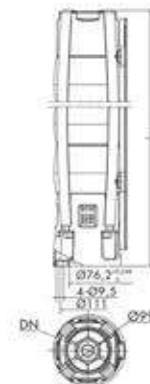



Accessories

ACCESSORIES

5 Way Connector →

Pressure Tank →

Pressure Gauge →

Pressure Control →

Automatic Pump
Control →

VA-MA provides you with all accessories, pressure control & automatic pump control with different adjustable ways.

MADE IN ITALY

5 WAY CONNECTOR

DESCRIPTION & APPLICATIONS:

Five-way connector is used to integrate pressure gauge, pressure switch and pressure tank with pump and output pipe. With easy way install because of it is smart design of hex key.

use in domestic, industrial, irrigation and water systems

MAIN FEATURES:

Material: brass

Weight: 320 gm

Length: 10 cm

Max pressure: 12 bar

PH of transfer liquid: 6.5-8.5



PRESSURE GAUGE

DESCRIPTION & APPLICATIONS:

Pressure gauge it is an indicator for pump pressure. With large lid and white background to view the start and stop pressure set.

use in domestic, industrial, irrigation and water systems

MAIN FEATURES:

Material: brass / Nickel Chrome

Pressure range: 0-12 bar

Pressure unit: psi or bar



PRESSURE TANK

MAIN FEATURES:

- 19 LITRE
- STAINLESS STEEL CONECTION
- 2 YEARS WARNTY



DESCRIPTION:

Pressure tank to be applied to water pump system and protecting water hammer. Pressure tank is made of natural polypropylene liner and high quality rubber diaphragm which is approved by FDA. Use in domestic, industrial, irrigation and water systems.

MAIN FEATURES

- Volume of 19 liters.
- Stainless steel connector.
- Single diaphragm design.
- Natural polypropylene liner.
- Double polyurethane, senior epoxy paint coating.
- Airtight O-ring sealed bonnet.
- Fully tested.
- Without any maintenance.
- Two years' warranty.



PS-02

DESCRIPTION & APPLICATIONS:

Pressure switch start and stop the water pump automatically according to the pressure setting by customer's needs.

It is used in water systems.
use in domestic, industrial, irrigation and water systems.

MAIN FEATURES:

Pressure range:	20-100 psi
Rated current:	12 A
Rated voltage:	240 V
Frequency:	50 Hz
Protection degree:	IP20
Connector size:	¼ " female
Max ambient temperature:	40
Max water temperature:	60
Max power:	1.1 KW



PC-2

DESCRIPTION & APPLICATIONS:

Pressure switch start and stop the water pump automatically according to the pressure setting by customer's needs.

It is used in water systems.
use in domestic, industrial, irrigation and water systems.

MAIN FEATURES:

Pressure range:	15-60 psi
Rated current:	12 A
Rated voltage:	240 V
Frequency:	50 Hz
Protection degree:	IP54
Connector size:	¼ " female
Max ambient temperature:	40
Max water temperature:	60
Max power:	1.1 KW



PS-02B

DESCRIPTION & APPLICATIONS:

Pressure switch start and stop the water pump automatically according to the pressure setting by customer's needs.

It is used in water systems.

use in domestic, industrial, irrigation and water systems.

MAIN FEATURES:

Pressure range:	20-100 psi
Rated current:	12 A
Rated voltage:	240 V
Frequency:	50 Hz
Protection degree:	IP20
Connector size:	1/4 " female
Max ambient temperature:	40
Max water temperature:	60
Max power:	2.2 KW



PS-9A

DESCRIPTION & APPLICATIONS:

Pressure switch interrupts the electric connection between the line and the load when the pressure decrease below the setting value. It is used in water systems to protect pump damage.

use in domestic, industrial, irrigation and water systems.

MAIN FEATURES:

Pressure range:	0.1-2.0 psi
Rated current:	12 A
Rated voltage:	240 V
Frequency:	50 Hz
Protection degree:	IP54
Connector size:	1/4 " male
Max ambient temperature:	40
Max water temperature:	60
Max power:	2.2 KW



PS-13

DESCRIPTION & APPLICATIONS:

PS-13 is an automatic pump control used to stop and start the pump automatically and stop the pump in the case of water shortage.

After power cut off, it can restart the pump automatically when the power on. Starting pressure is adjustable during installation.

use in domestic, industrial, irrigation and water systems.



MAIN FEATURES:

Starting pressure:	1.5 or 2.2 bar
Max rated current:	10 A
Max allowable pressure:	10 bar
Rated voltage:	220 V
Frequency:	50 Hz
Protection degree:	IP65
Max power:	1.1 KW
Max ambient temperature:	40
Max water temperature:	60
Joint screw:	G1" male



PS-15

DESCRIPTION & APPLICATIONS:

PS-15 is an automatic pump control used to stop and start the pump automatically and stop the pump in the case of water shortage.

Automatic restart after water shortage, the restart interval time is 8 sec, 30 sec, 1 min, 10 min, 30 min, 1 hr, 2 hr.

After power cut off, it can restart the pump automatically when the power on.

Starting pressure is adjustable during installation.

use in domestic, industrial, irrigation and water systems



MAIN FEATURES:

Starting pressure:	1.5 or 2.2 bar
Max rated current:	10 A
Max allowable pressure:	10 bar
Rated voltage:	220 V
Frequency:	50 Hz
Protection degree:	IP65
Max power:	1.1 KW
Max ambient temperature:	40
Max water temperature:	60
Joint screw:	G1" male



PS-19

DESCRIPTION & APPLICATIONS:

PS-19 is an automatic pump control used to stop and start the pump automatically and stop the pump in the case of water shortage. Automatic restart after water shortage, the restart interval time is 8 sec, 30 sec, 1 min, 10 min, 30 min, 1 hr, 2 hr, 2 hr recycle. After power cut off, it can restart the pump automatically when the power on. Starting pressure is adjustable during installation. use in domestic, industrial, irrigation and water systems.



MAIN FEATURES:

Starting pressure:	1.5 or 2.2 bar
Max rated current:	10 A
Max allowable pressure:	10 bar
Rated voltage:	220 V
Frequency:	50 Hz
Protection degree:	IP65
Max power:	1.1 KW
Max ambient temperature:	40
Max water temperature:	60
Joint screw:	G1" male



PS-53

DESCRIPTION & APPLICATIONS:

PS-53 is a digital automatic pump control used to stop and start the pump automatically and stop the pump in the case of water shortage.

Automatic restart after water shortage, the restart interval time is 8 sec, 30 sec, 1 min, 10 min, 30 min, 1 hr, 1 hr recycle.

Over-pressure protection, stop the pump automatically when the system pressure exceeds 10 bar.

Anti-stick protection, PS-53 will start the pump automatically by 1 time in 48hours to prevent the pump get stuck in condition of long time no use.

After power cut off, it can restart the pump automatically when the power on.

Built-in two working mode:

a) Automatic mode:

The control can adjust the starting pressure according to the pressure in the pipe and real-time monitoring.

With pressure sensor and LED display, to manager the system pressure value real-time no need to manual set, with this function, can avoid the problem occur because of wrong set of start pressure, such as the start pressure set not match with the pump lift will make the pump not start normally.

Applied to the any pump that the head from 10m-98m.

b) Normal mode:

manually set starting pressure, 0.5-6.0 bar adjustable, wide range of adjustment, easy to operate.

use in domestic, industrial, irrigation and water systems.

MAIN FEATURES:

Starting pressure:	0.5 - 6.0 bar	Protection degree:	IP65
Max rated current:	10 A	Max power:	1.1 KW
Max allowable pressure:	10 bar	Max ambient temperature:	40
Rated voltage:	85 - 265 V	Max water temperature:	60
Frequency:	50 Hz	Joint screw:	G1" male



PS-58 (P)

DESCRIPTION & APPLICATIONS:

PS-58 series is a digital automatic pump control used to stop and start the pump automatically and stop the pump in the case of water shortage.

Automatic restart after water shortage, the restart interval time is 8 sec, 30 sec, 1 min, 10 min, 30 min, 1 hr, 1 hr recycle.

Over-pressure protection, stop the pump automatically when the system pressure exceeds 10 bar.

Overload protection.

Anti-stick protection, PS-58 series will start the pump automatically by 1 time in 48hours to prevent the pump get stuck.

After power cut off, it can restart the pump automatically when the power on.



BUILT-IN TWO WORKING MODE:

a) Mode 1:

In this mode, only starting pressure can be set, pump will be stop working in its max head.

b) Mode 2:

Manually set starting pressure and stopping pressure, wide range of adjustment, easy to operate.

use in domestic, industrial, irrigation and water systems.

MAIN FEATURES:

Starting pressure:	0.5 - 6.0 bar
Max rated current:	10 / 16 A
Max allowable pressure:	10 bar
Rated voltage:	220 V
Frequency:	50 Hz
Protection degree:	IP65
Max power:	1.1 / 2.2 KW
Max ambient temperature:	40
Max water temperature:	60
Joint screw:	G1" male



PS-59

DESCRIPTION & APPLICATIONS:

PS-59 is an automatic pump control used to stop and start the pump automatically and stop the pump in the case of water shortage.

Manually set starting and stopping pressure.

start pressure can set from 1 - 6 bar adjustable and stop pressure can set from 2 - 10 bar, wide range of adjustment, easy to operate.

After power cut off, it can restart the pump automatically when the power on.

Starting pressure is adjustable during installation. use in domestic, industrial, irrigation and water systems



MAIN FEATURES:

Starting pressure:	1 - 6 bar
Stopping pressure:	2 - 10 bar
Max rated current:	10 A
Max allowable pressure:	10 bar
Rated voltage:	220 V
Frequency:	50 Hz
Protection degree:	IP65
Max power:	1.1 KW
Max ambient temperature:	40
Max water temperature:	60
Joint screw:	G1" male



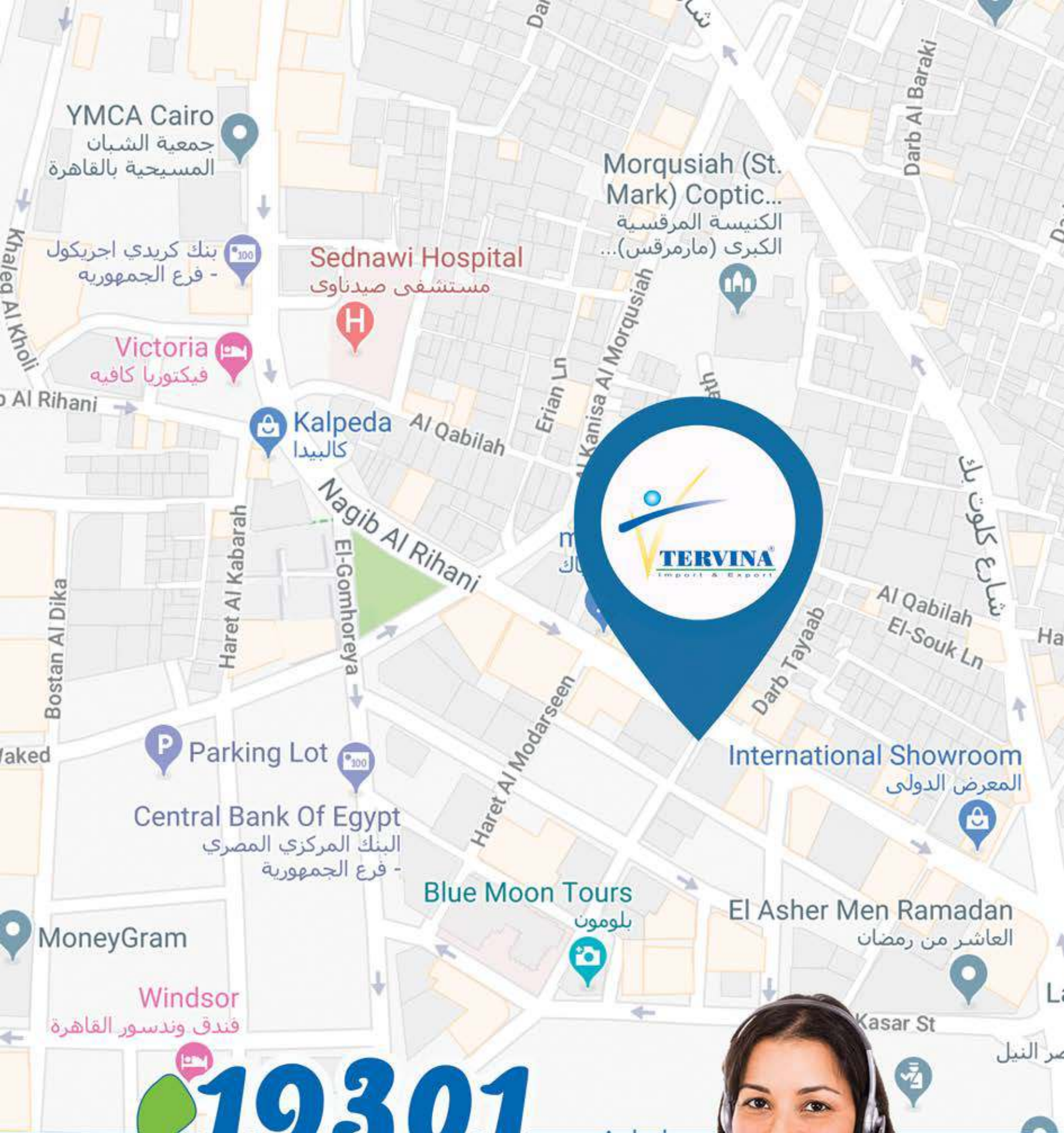

 **19301**

 47 Nagiub El-Rehany St.
 Down Town – Cairo
 02/27878876 – 02/25920900
01015053300





Notes

A series of horizontal blue lines for writing notes, covering the majority of the page below the header.



E-MAIL : INFO@VAMAPUMP.COM - SALES@VAMAPUMP.COM

WWW.VAMAPUMP.COM

